

THE ROLE OF THE HEADPHONE COUPLING CAPACITOR

INTRODUCTION

There is a relentless pursuit to reduce size and include more functions within portable equipment with audio capabilities. As a result there is less and less available space within portable devices for new circuitry. A common question is continually asked, "Can the headphone coupling capacitor be a smaller value and therefore size". The simple answer is maybe, but only at a reduction in frequency response.

This Application Note discusses the physics of the audio output coupling capacitor and why it needs to be a large value for optimal audio bandwidth performance.

THE HEADPHONE SET

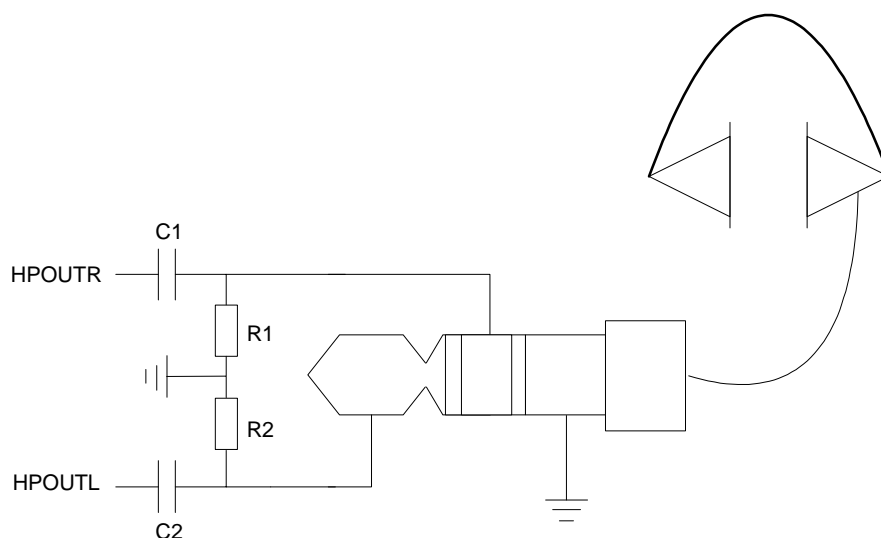

Figure 1 Standard Headphone Jack Plug and Headphones

Common load impedance for a standard stereo headphone set is in the region of 8Ω to 56Ω on Wolfson Evaluation Boards.

In order to provide a simple highpass filter for the connection of high impedance loads, such as active speakers or audio measurement equipment, load resistors R1 and R2 are provided. The value of R1 and R2 is chosen so that there will be minimum effect on the output when a low impedance load is connected. For applications that will only be connected to low impedance, i.e. 8Ω to 56Ω loads, R1 and R2 are not required.

The impedance of these load resistors on Wolfson Evaluation Boards is usually $47k\Omega$ as demonstrated on the WM8731 Evaluation Board headphone output by R43 and R45, Figure 2. C57 and C59 represent C1 and C2.

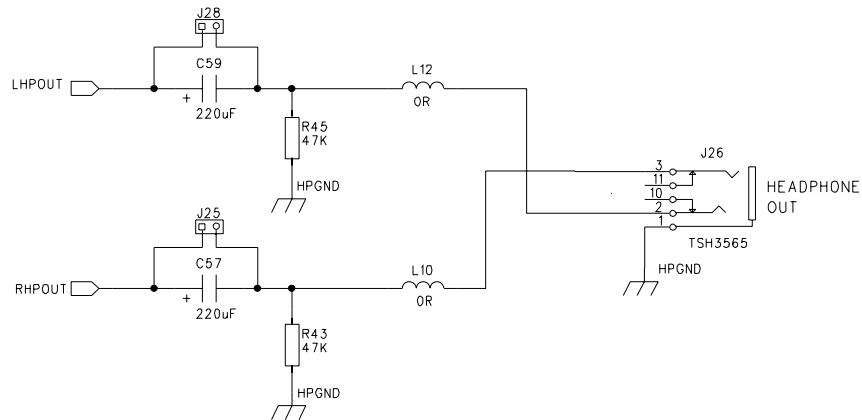

Figure 2 WM8731 Headphone Output

THE EFFECT OF THE AC COUPLING/DC BLOCKING CAPACITOR

Most DAC devices provide an audio output that has a dc component, usually at the mid-rail analogue supply voltage. Therefore the main role of the capacitor, that links the audio output of the DAC device and jack socket, is for dc blocking. A side effect of including this capacitor is to produce a High Pass Filter at the output. To maintain a satisfactory audio bandwidth this filter needs to have a sensible low frequency cut-off in the lower auditory range of the human ear.

The frequency response of the output is determined by the well-known formula:

$$f_c = \frac{1}{2\pi R_L C_c}$$

where R_L is the sum of headphone and the output load resistor impedances. (R_1 or R_2 in parallel with headphone impedance).

C_c is the coupling capacitor. (C_1 or C_2).

f_c is the low frequency cut-off.

The audio output coupling capacitor performs best with a value greater than 100µF. Wolfson Evaluation Boards employ 220µF capacitors in this role for optimal frequency response. Table 1 shows some examples of cut-off frequencies expected in common headphone output circuits.

Load Impedance R_L	Coupling Capacitor C_c	Low Frequency Cut-off f_c
8Ω	220µF	90Hz
16Ω	220µF	45Hz
32Ω	220µF	22Hz

Table 1 Load Impedance vs Low Frequency Cut-off

FREQUENCY RESPONSE FOR INCREASING COUPLING CAPACITANCE

The following performance plots show how frequency response improves as the coupling capacitor value increases. The plots were measured using a 0dBFS input signal and a standard 32Ω load, apart from Figure 3 which shows a reference plot with no load. The dotted lines depict the 3dB low frequency cut-off point, as expected the cut-off frequency decreases inversely with capacitor value.

Wolfson Microelectronics WM8731-EV1 DAC to HP_Out Frequency Response $C_c = 220\mu\text{F}$ $R_L = \text{No Load}$
Signal = 0dBFS, 24-bit I2S, 256fs ($f_s = 48\text{kHz}$); Slave Mode

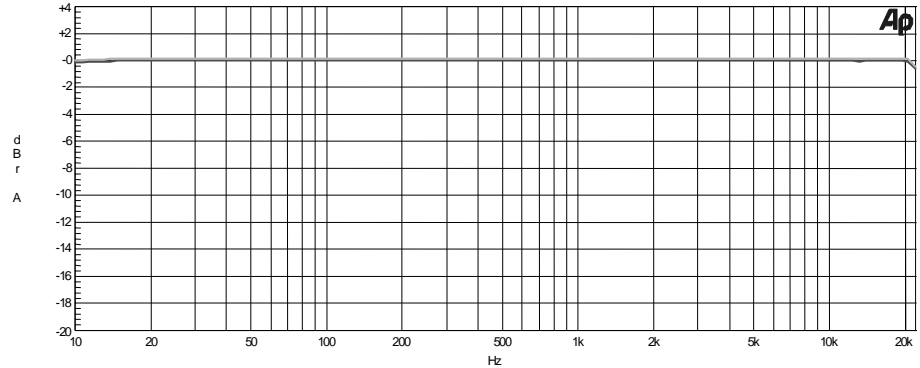

Figure 3 Evaluation Board Headphone Output Frequency Response - No Load $C_c = 220\mu\text{F}$

Wolfson Microelectronics WM8731-EV1 DAC to HP_Out Frequency Response $C_c = 78\mu\text{F}$ $R_L = 32\text{ohm}$
Signal = 0dBFS, 24-bit I2S, 256fs ($f_s = 48\text{kHz}$); Slave Mode

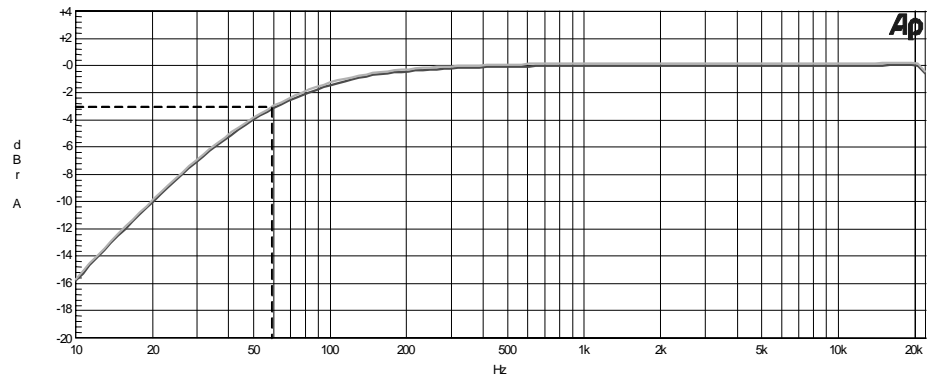

Figure 4 Evaluation Board Headphone Output Frequency Response - $R_L = 32\Omega$ $C_c = 78\mu\text{F}$

Wolfson Microelectronics WM8731-EV1 DAC to HP_Out Frequency Response $C_c = 110\mu\text{F}$ $R_L = 32\text{ohm}$
Signal = 0dBFS, 24-bit I2S, 256fs ($f_s = 48\text{kHz}$); Slave Mode

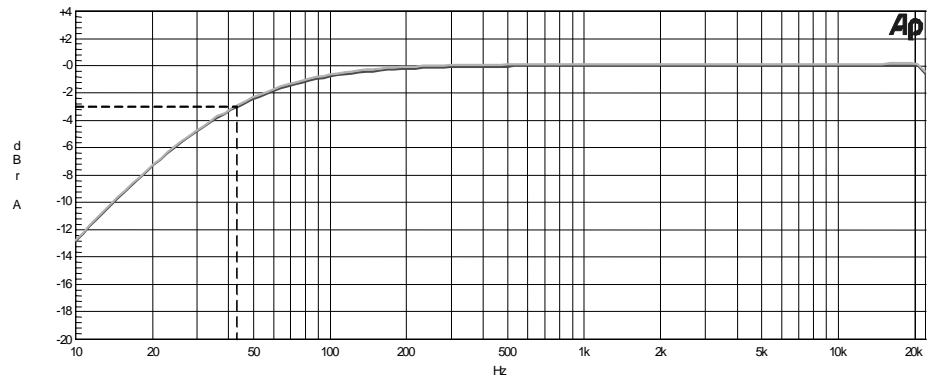

Figure 5 Evaluation Board Headphone Output Frequency Response - $R_L = 32\Omega$ $C_c = 110\mu\text{F}$

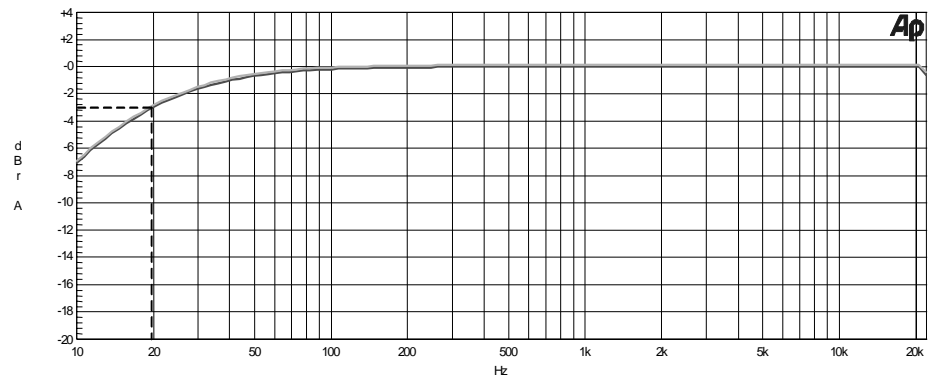

Figure 6 Evaluation Board Headphone Output Frequency Response - RL = 32Ω CC = 220µF

COMPROMISES

Now that the optimal frequency response scenario has been explained the question still has to be answered whether a reduction can be made in coupling capacitor size to allow space/cost saving. It can be seen from the above information that any reduction in capacitor value will affect audio bandwidth performance. It is therefore up to the customer as to whether a reduction in performance is acceptable. The following information may assist making this decision.

HEADPHONE QUALITY

If it is likely that poorer quality headphones are to be used, which generally have poorer frequency response, then the low frequency cut-off at the audio output can be compromised to match that of the headphones. It should be considered that there is always the possibility that a good quality headphone and keen hearing will reveal this lack of quality.

AUDITORY RESPONSE

The response of the human ear, auditory response, is often not as sensitive or as linear as some good quality headphones. One effect called masking is due to the ability of the ear to interpret louder sounds while masking out the softer ones. Low frequency sounds below 200Hz are not perceived as well as frequencies above this up to 10kHz.

Another source of assistance is due to the wavelength of sounds at low frequencies. The brain determines distance by delay, low frequencies have long wavelengths and therefore sound is perceived at the ears at the same time. Because this delay is not available at long wavelengths, the source cannot be pinpointed. At higher frequencies, delay and therefore direction is much more noticeable, resulting in higher frequency sounds being perceived more strongly over low frequency ones. This is the reason why sub-woofers can effectively be placed anywhere in a room.

CONCLUSION

To achieve optimal performance the audio output AC coupling/DC blocking capacitor should be large, in the range 100µF to 1000µF. Wolfson find that a 220µF capacitor gives optimal performance versus size benefits. Using values smaller than this may be acceptable in the end application, but with the above proviso's.

APPLICATION SUPPORT

If you require more information or require technical support please contact Wolfson Microelectronics Applications group through the following channels:

Email: apps@wolfsonmicro.com
 Telephone: (+44) 131 272 7070
 Fax: (+44) 131 272 7001
 Mail: Applications at the address on the last page.

or contact your local Wolfson representative.

Additional information may be made available from time to time on our web site at:

<http://www.wolfsonmicro.com>

IMPORTANT NOTICE

Wolfson Microelectronics Ltd (WM) reserve the right to make changes to their products or to discontinue any product or service without notice, and advise customers to obtain the latest version of relevant information to verify, before placing orders, that information being relied on is current. All products are sold subject to the WM terms and conditions of sale supplied at the time of order acknowledgement, including those pertaining to warranty, patent infringement, and limitation of liability.

WM warrants performance of its products to the specifications applicable at the time of sale in accordance with WM's standard warranty. Testing and other quality control techniques are utilised to the extent WM deems necessary to support this warranty. Specific testing of all parameters of each device is not necessarily performed, except those mandated by government requirements.

In order to minimise risks associated with customer applications, adequate design and operating safeguards must be used by the customer to minimise inherent or procedural hazards.

WM assumes no liability for applications assistance or customer product design. WM does not warrant or represent that any license, either express or implied, is granted under any patent right, copyright, mask work right, or other intellectual property right of WM covering or relating to any combination, machine, or process in which such products or services might be or are used. WM's publication of information regarding any third party's products or services does not constitute WM's approval, license, warranty or endorsement thereof.

Reproduction of information from the WM web site or datasheets is permissible only if reproduction is without alteration and is accompanied by all associated warranties, conditions, limitations and notices. Representation or reproduction of this information with alteration voids all warranties provided for an associated WM product or service, is an unfair and deceptive business practice, and WM is neither responsible nor liable for any such use.

Resale of WM's products or services with statements different from or beyond the parameters stated by WM for that product or service voids all express and any implied warranties for the associated WM product or service, is an unfair and deceptive business practice, and WM is neither responsible nor liable for any such use.

ADDRESS:

Wolfson Microelectronics Ltd
20 Bernard Terrace
Edinburgh
EH8 9NX
United Kingdom

Tel :: +44 (0)131 272 7000
Fax :: +44 (0)131 272 7001
Email :: apps@wolfsonmicro.com