

## 24-Bit, 192kHz Stereo ADC

### DESCRIPTION

The WM8785 is a stereo audio ADC with differential inputs designed for high performance recordable media applications. Data is provided as a PCM output.

Stereo 24-bit multi-bit sigma-delta ADCs are used with digital audio output word lengths of 16 to 32 bits, and sampling rates from 8kHz to 192kHz. The device has a selectable high pass filter to remove residual DC offsets. The device also supports a TDM bus for data out.

The device is controlled via a 2 or 3 wire serial interface. The interface provides access to all features including oversampling rate, audio format, powerdown, master/slave control and digital signal manipulation. The device is supplied in a 20-lead SSOP package.

### FEATURES

- SNR 111dB ('A' weighted @ 48kHz)
- THD -102dB (at -0.1dB)
- Sampling Frequency: 8 – 192kHz
- 2 or 3 Wire Microprocessor Control Interface
- Master or Slave Clocking Mode
- Programmable Audio Data Interface Modes
  - I<sup>2</sup>S, Left, Right Justified or DSP
  - 16/20/24/32 bit Word Lengths
- A TDM bus is supported for data out
- Supply Voltages
  - Analogue 4.5 to 5.5V
  - Digital core: 2.7V to 3.6V
- 20-lead SSOP package

### APPLICATIONS

- Recordable DVD Players
- Personal Video Recorders
- High End Sound Cards
- Studio Audio Processing Equipment

### BLOCK DIAGRAM

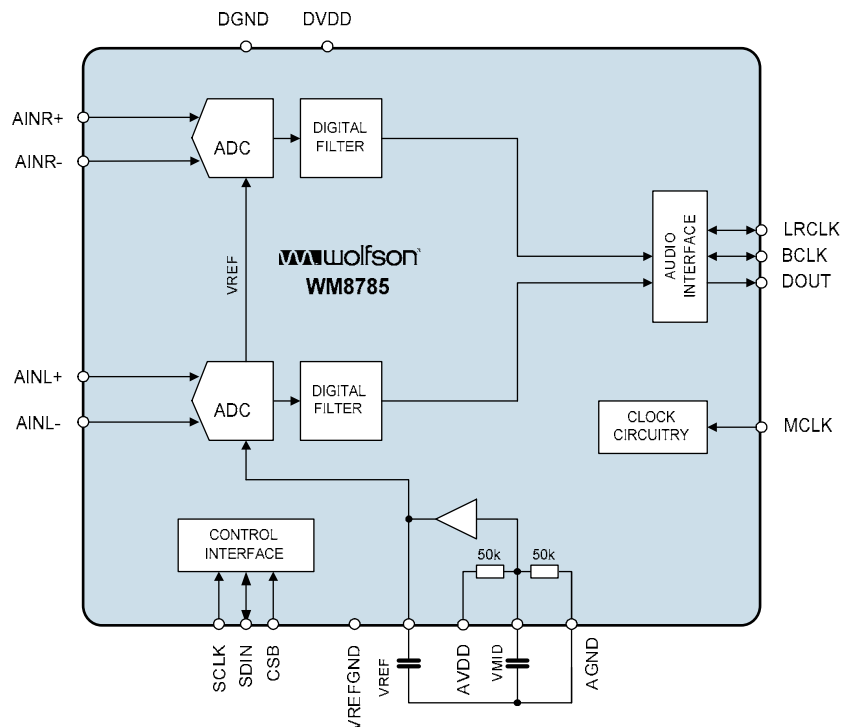

## TABLE OF CONTENTS

<b>DESCRIPTION .....</b>	<b>1</b>
<b>FEATURES.....</b>	<b>1</b>
<b>APPLICATIONS .....</b>	<b>1</b>
<b>BLOCK DIAGRAM .....</b>	<b>1</b>
<b>TABLE OF CONTENTS .....</b>	<b>2</b>
<b>PIN CONFIGURATION.....</b>	<b>3</b>
<b>ORDERING INFORMATION .....</b>	<b>3</b>
<b>PIN DESCRIPTION .....</b>	<b>4</b>
<b>ABSOLUTE MAXIMUM RATINGS.....</b>	<b>5</b>
<b>RECOMMENDED OPERATING CONDITIONS .....</b>	<b>5</b>
<b>ELECTRICAL CHARACTERISTICS .....</b>	<b>6</b>
TERMINOLOGY .....	7
<b>SIGNAL TIMING REQUIREMENTS .....</b>	<b>8</b>
SYSTEM CLOCK TIMING .....	8
AUDIO INTERFACE TIMING – MASTER MODE, PCM DATA .....	8
AUDIO INTERFACE TIMING – SLAVE MODE, PCM DATA .....	9
CONTROL INTERFACE TIMING – 3-WIRE MODE .....	9
CONTROL INTERFACE TIMING – 2-WIRE MODE .....	10
POWER-ON RESET .....	11
<b>DIGITAL FILTER CHARACTERISTICS .....</b>	<b>12</b>
TERMINOLOGY .....	12
HIGH PASS FILTER TRANSFER CHARACTERISTIC.....	12
<b>FILTER RESPONSES.....</b>	<b>13</b>
<b>DEVICE DESCRIPTION.....</b>	<b>17</b>
INTRODUCTION.....	17
DIGITAL AUDIO INTERFACE .....	17
DIGITAL HIGH PASS.....	21
DATA OUT PIN DISABLE .....	22
CONTROL INTERFACE.....	22
TIME DIVISION MULTIPLEXED DATA OUT.....	23
TDM SELECTION .....	24
OVERSAMPLING RATIOS AND SIGMA-DELTA MODULATOR FREQUENCY.....	27
MASTER CLOCK AND AUDIO SAMPLE RATES.....	27
MLCK AND LRCLK PHASE RELATIONSHIP .....	28
POWER DOWN CONTROL.....	28
REGISTER MAP .....	29
<b>APPLICATIONS INFORMATION .....</b>	<b>30</b>
RECOMMENDED EXTERNAL COMPONENTS .....	30
RECOMMENDED PCB LAYOUT .....	31
<b>PACKAGE DIMENSIONS .....</b>	<b>32</b>
<b>IMPORTANT NOTICE .....</b>	<b>33</b>
ADDRESS:.....	33

## PIN CONFIGURATION

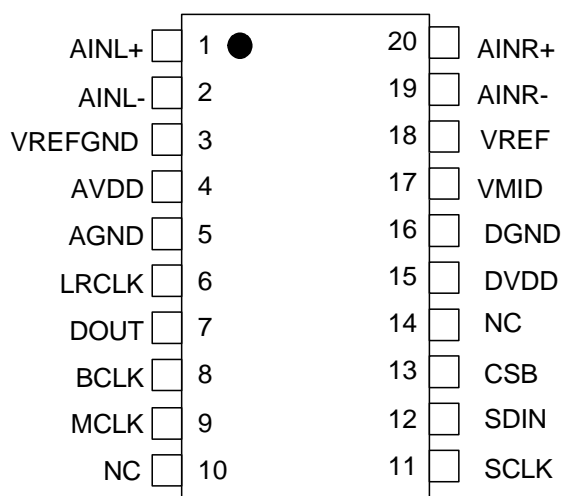

## ORDERING INFORMATION

ORDER CODE	TEMPERATURE RANGE	PACKAGE	MOISTURE SENSITIVITY LEVEL	PEAK SOLDERING TEMPERATURE
WM8785GEDS/V	-40°C to +85°C	20-lead SSOP (Pb-free)	MSL3	260°C
WM8785GEDS/RV	-40°C to +85°C	20-lead SSOP (Pb-free, tape and reel)	MSL3	260°C

**Note:**

Reel quantity = 2,000

**PIN DESCRIPTION**

<b>PIN</b>	<b>NAME</b>	<b>TYPE</b>	<b>DESCRIPTION</b>
1	AINL+	Analogue Input	Left Channel Positive Input
2	AINL-	Analogue Input	Left Channel Negative Input
3	VREFGND	Analogue Reference	Negative Reference Connection
4	AVDD	Supply	Analogue Supply
5	AGND	Supply	Analogue Ground (return path for AVDD)
6	LRCLK	Digital Input / Output	Audio Interface Left / Right Clock
7	DOUT	Digital Output	ADC Digital Audio Data
8	BCLK	Digital Input / Output	Audio Interface Bit Clock
9	MCLK	Digital Input	Master Clock
10	NC	NC	No Connection
11	SCLK	Digital Input	Control Interface Clock Input / 2 wire output
12	SDIN	Digital Input / Output	Control Interface Data Input
13	CSB	Digital Input	Chip Select / Control Interface Format Selection / 3 wire address select
14	NC	NC	No connection
15	DVDD	Supply	Digital Supply
16	DGND	Supply	Digital Ground (return path for DVDD)
17	VMID	Analogue Output	Midrail Voltage Decoupling Capacitor
18	VREF	Analogue Reference	Reference Voltage Decoupling Capacitor
19	AINR-	Analogue Input	Right Channel Negative Input
20	AINR+	Analogue Input	Right Channel Positive Input

## ABSOLUTE MAXIMUM RATINGS

Absolute Maximum Ratings are stress ratings only. Permanent damage to the device may be caused by continuously operating at or beyond these limits. Device functional operating limits and guaranteed performance specifications are given under Electrical Characteristics at the test conditions specified.



ESD Sensitive Device. This device is manufactured on a CMOS process. It is therefore generically susceptible to damage from excessive static voltages. Proper ESD precautions must be taken during handling and storage of this device.

Wolfson tests its package types according to IPC/JEDEC J-STD-020B for Moisture Sensitivity to determine acceptable storage conditions prior to surface mount assembly. These levels are:

MSL1 = unlimited floor life at <30°C / 85% Relative Humidity. Not normally stored in moisture barrier bag.

MSL2 = out of bag storage for 1 year at <30°C / 60% Relative Humidity. Supplied in moisture barrier bag.

MSL3 = out of bag storage for 168 hours at <30°C / 60% Relative Humidity. Supplied in moisture barrier bag.

The Moisture Sensitivity Level for each package type is specified in Ordering Information.

CONDITION	MIN	MAX
Digital supply voltage	-0.3V	+3.63V
Analogue supply voltage	-0.3V	+7V
Voltage range digital inputs	DGND -0.3V	DVDD + 0.3V
Voltage range analogue inputs	AGND -0.3V	AVDD +0.3V
Master Clock Frequency		40MHz
Operating temperature range, T <sub>A</sub>	-40°C	+85°C
Storage temperature after soldering	-65°C	+150°C

**Note:** Analogue and digital grounds must always be within 0.3V of each other.

## RECOMMENDED OPERATING CONDITIONS

PARAMETER	SYMBOL	TEST CONDITIONS	MIN	TYP	MAX	UNIT
Digital supply range	DVDD		2.7		3.6	V
Analogue supply range	AVDD		4.5		5.5	V
Ground	DGND,AGND			0		V

## ELECTRICAL CHARACTERISTICS

### Test Conditions

DVDD = 3.3V, AVDD = 5.0V, T<sub>A</sub> = +25°C, 1kHz signal, A-weighted, fs = 48kHz, MCLK = 256fs, 24-bit audio data, Slave Mode unless otherwise stated.

PARAMETER	SYMBOL	TEST CONDITIONS	MIN	TYP	MAX	UNIT
<b>ADC Performance</b>						
Full Scale Input Signal Level (for ADC 0dB Input)				2.0		V <sub>rms</sub>
Input resistance				10		kΩ
Input capacitance				10		pF
Signal to Noise Ratio (Note 1,2,4)	SNR	A-weighted, @ fs = 48kHz	102	111		dB
		Unweighted, @ fs = 48kHz		108		dB
Signal to Noise Ratio (Note 1,2,4)	SNR	A-weighted, @ fs = 96kHz		111		dB
		Unweighted, @ fs = 96kHz		108		dB
Signal to Noise Ratio (Note 1,2,4)	SNR	A-weighted, @ fs = 192kHz		111		dB
		Unweighted, @ fs = 192kHz		108		dB
Total Harmonic Distortion	THD	1kHz, -0.1dB Full Scale @ fs = 48kHz		-102	-92	dB
		1kHz, -0.1dB Full Scale @ fs = 96kHz		-102		dB
		1kHz, -0.1dB Full Scale @ fs = 192kHz		-102		dB
Total Harmonic Distortion	THD	1kHz, -0.1dB Full Scale @ fs = 48kHz		0.0008	0.0025	%
		1kHz, -0.1dB Full Scale @ fs = 96kHz		0.0008		%
		1kHz, -0.1dB Full Scale @ fs = 192kHz		0.0008		%
Dynamic Range	DNR	-60dBFS	102	111		dB
Channel Level Matching		20kHz signal		0.1		dB
Power Supply Rejection Ratio	PSRR	1kHz 100mVpp, applied to AVDD, DVDD		50		dB
		20Hz to 20kHz 100mVpp		45		dB
<b>Digital Logic Levels (CMOS Levels)</b>						
Input LOW level	V <sub>IL</sub>				0.3 x DVDD	V
Input HIGH level	V <sub>IH</sub>		0.7 x DVDD			V
Input leakage current			-1	±0.2	+1	μA
Input capacitance				5		pF
Output LOW	V <sub>OL</sub>	I <sub>OL</sub> =1mA			0.1 x DVDD	V
Output HIGH	V <sub>OH</sub>	I <sub>OH</sub> = -1mA	0.9 x DVDD			V
<b>Analogue Reference Levels</b>						
Midrail Reference Voltage	VMID	AVDD to VMID and VMID to VREFGND	-3%	AVDD/2	+3%	V
Potential Divider Resistance	R <sub>VMID</sub>	AVDD to VMID and VMID to GND		50		kΩ
Buffered Reference Voltage	VREF		-3%	0.8 x AVDD	+3%	V

**Test Conditions**

DVDD = 3.3V, AVDD = 5.0V, T<sub>A</sub> = +25°C, 1kHz signal, A-weighted, fs = 48kHz, MCLK = 256fs, 24-bit audio data, Slave Mode unless otherwise stated.

PARAMETER	SYMBOL	TEST CONDITIONS	MIN	TYP	MAX	UNIT
<b>Supply Current</b>						
Analogue supply current				27		mA
Digital supply current				5		mA
Power Down				22		uA

**Note:**

1. VMID is decoupled with 10uF and 0.1uF capacitors close to the device package. Smaller capacitors may reduce performance.

**TERMINOLOGY**

1. Signal-to-noise ratio (dB) – Ratio of output level with 1kHz full scale input, to the output level with all zeros into the digital input, over a 20Hz to 20kHz bandwidth. (No Auto-zero or Automute function is employed in achieving these results).
2. Dynamic range (dB) - DR is a measure of the difference between the highest and lowest portions of a signal. Normally a THD+N measurement at 60dB below full scale. The measured signal is then corrected by adding the 60dB to it. (e.g. THD+N @ -60dB= -32dB, DR= 92dB).
3. THD+N (dB) - THD+N is a ratio, of the rms values, of (Noise + Distortion)/Signal.
4. Channel Separation (dB) - Also known as Cross-Talk. This is a measure of the amount one channel is isolated from the other. Normally measured by sending a full scale signal down one channel and measuring the other.
5. All performance measurements are done with a 20kHz low pass filter, and where noted an A-weight filter, except where noted. Failure to use such a filter will result in higher THD+N and lower SNR and Dynamic Range readings than are found in the Electrical Characteristics. The low pass filter removes out of band noise; although this is not audible, it may affect dynamic specification values

## SIGNAL TIMING REQUIREMENTS

### SYSTEM CLOCK TIMING

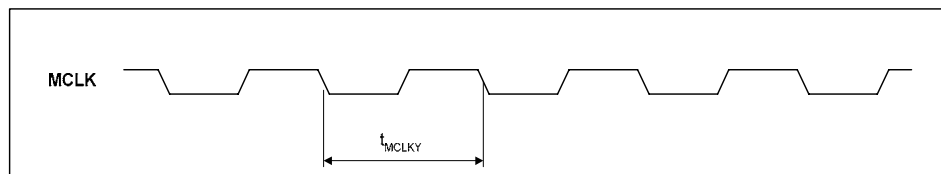

Figure 1 System Clock Timing Requirements

**Test Conditions**

DVDD = 3.3V, DGND = 0V,  $T_A = +25^\circ\text{C}$ , Slave Mode,  $f_s = 48\text{kHz}$ , MCLK = 256fs, 24-bit data, unless otherwise stated.

PARAMETER	SYMBOL	MIN	TYP	MAX	UNIT
<b>System Clock Timing Information</b>					
MCLK System clock cycle time	$T_{MCLKY}$	25			ns
MCLK duty cycle	$T_{MCLKDS}$	60:40		40:60	

### AUDIO INTERFACE TIMING – MASTER MODE, PCM DATA

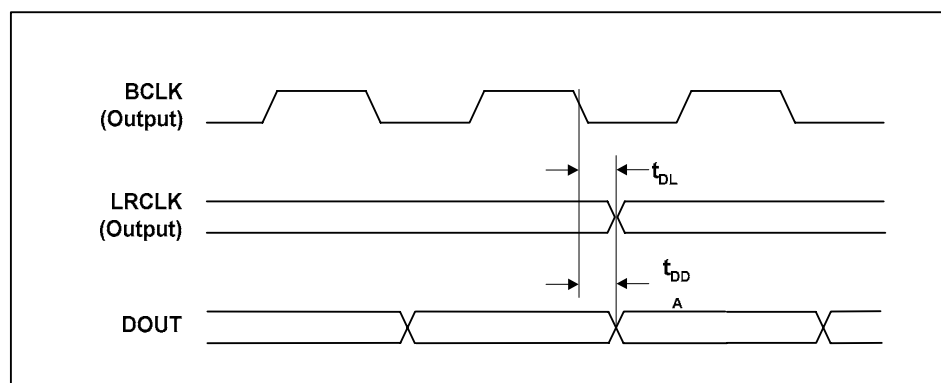

Figure 2 Digital Audio Data Timing – Master Mode (see Control Interface)

**Test Conditions**

DVDD = 3.3V, DGND = 0V,  $T_A = +25^\circ\text{C}$ , Master Mode,  $f_s = 48\text{kHz}$ , MCLK = 256fs, 24-bit data, unless otherwise stated.

PARAMETER	SYMBOL	MIN	TYP	MAX	UNIT
<b>Audio Data Input Timing Information</b>					
LRCLK propagation delay from BCLK falling edge	$t_{DL}$	0		10	ns
DOUT propagation delay from BCLK falling edge	$t_{DDA}$	0		11	ns

**AUDIO INTERFACE TIMING – SLAVE MODE, PCM DATA**

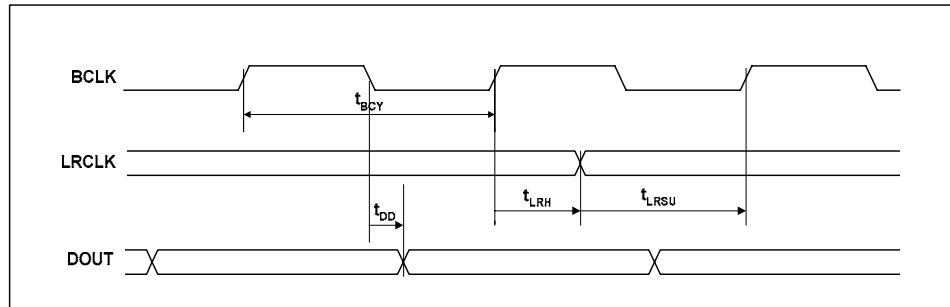

Figure 3 Digital Audio Data Timing – Slave Mode

**Test Conditions**

DVDD = 3.3V, DGND = 0V, T<sub>A</sub> = +25°C, Slave Mode, fs = 48kHz, MCLK = 256fs, 24-bit data, unless otherwise stated.

PARAMETER	SYMBOL	MIN	TYP	MAX	UNIT
<b>Audio Data Input Timing Information</b>					
BCLK cycle time	t <sub>BCY</sub>	25			ns
LRCLK set-up time to BCLK rising edge	t <sub>LRSU</sub>	10			ns
LRCLK hold time from BCLK rising edge	t <sub>LRH</sub>	10			ns
DOUT propagation delay from BCLK falling edge	t <sub>DD</sub>	0		11	ns

**CONTROL INTERFACE TIMING – 3-WIRE MODE**

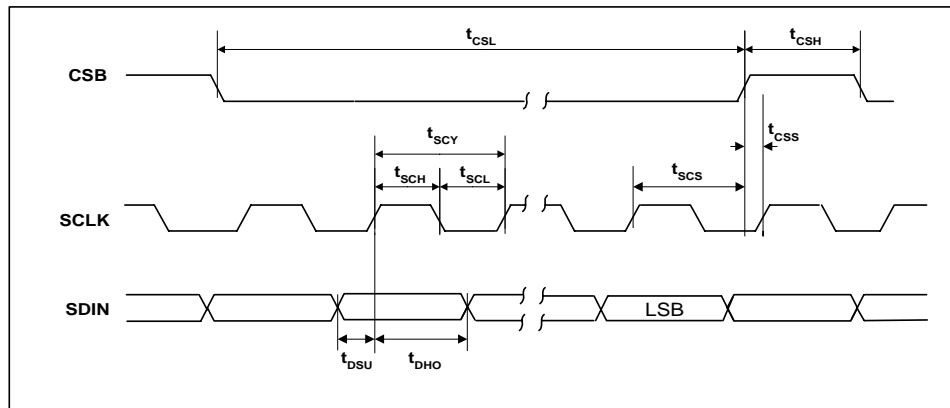

Figure 4 Control Interface Timing – 3-Wire Serial Control Mode

**Test Conditions**

DVDD = 3.3V, DVDD = 3.3V, DGND = 0V, T<sub>A</sub> = +25°C, Slave Mode, fs = 48kHz, MCLK = 256fs, 24-bit data, unless otherwise stated.

PARAMETER	SYMBOL	MIN	TYP	MAX	UNIT
<b>Program Register Input Information</b>					
SCLK rising edge to CSB rising edge	t <sub>SCS</sub>	80			ns
SCLK pulse cycle time	t <sub>SCY</sub>	200			ns
SCLK pulse width low	t <sub>SCL</sub>	80			ns
SCLK pulse width high	t <sub>SCH</sub>	80			ns
SDIN to SCLK set-up time	t <sub>DSU</sub>	40			ns
SCLK to SDIN hold time	t <sub>DHO</sub>	40			ns
CSB pulse width low	t <sub>CSL</sub>	40			ns
CSB pulse width high	t <sub>CSH</sub>	40			ns
CSB rising to SCLK rising	t <sub>CSS</sub>	40			ns
Pulse width of spikes that will be suppressed	t <sub>ps</sub>	4		6	ns

**CONTROL INTERFACE TIMING – 2-WIRE MODE**

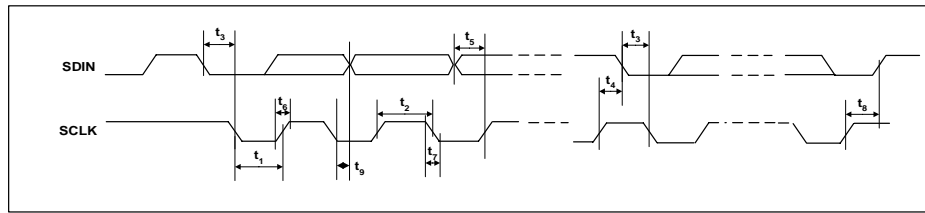

**Figure 5 Control Interface Timing – 2-Wire Serial Control Mode**

**Test Conditions**

DVDD = 3.3V, DVDD = 3.3V, DGND = 0V,  $T_A = +25^\circ\text{C}$ , Slave Mode,  $f_s = 48\text{kHz}$ , MCLK = 256fs, 24-bit data, unless otherwise stated.

PARAMETER	SYMBOL	MIN	TYP	MAX	UNIT
Program Register Input Information					
SCLK Frequency		0		5	MHz
SCLK Low Pulse-Width	$t_1$	80			ns
SCLK High Pulse-Width	$t_2$	80			us
Hold Time (Start Condition)	$t_3$	600			ns
Setup Time (Start Condition)	$t_4$	600			ns
Data Setup Time	$t_5$	100			ns
SDIN, SCLK Rise Time	$t_6$			300	ns
SDIN, SCLK Fall Time	$t_7$			300	ns
Setup Time (Stop Condition)	$t_8$	600			ns
Data Hold Time	$t_9$			900	ns
Pulse width of spikes that will be suppressed	$t_{ps}$	4		6	ns

**POWER-ON RESET**

The WM8785 has an internal power-on reset circuit. The reset sequence is entered at power-on or power-up (DVDD). Until the internal reset is removed, DOUT is forced to zero. DOUT remains zero for a count equal to 32 sample clocks, after power up. (This count is driven by MCLK and is independent of any external LRCLK).

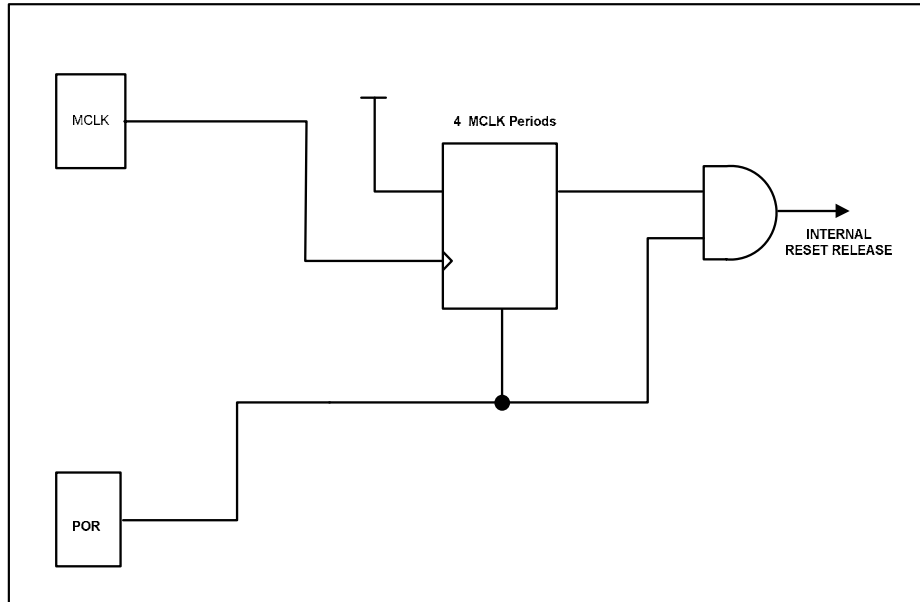

Figure 6 POR Circuit

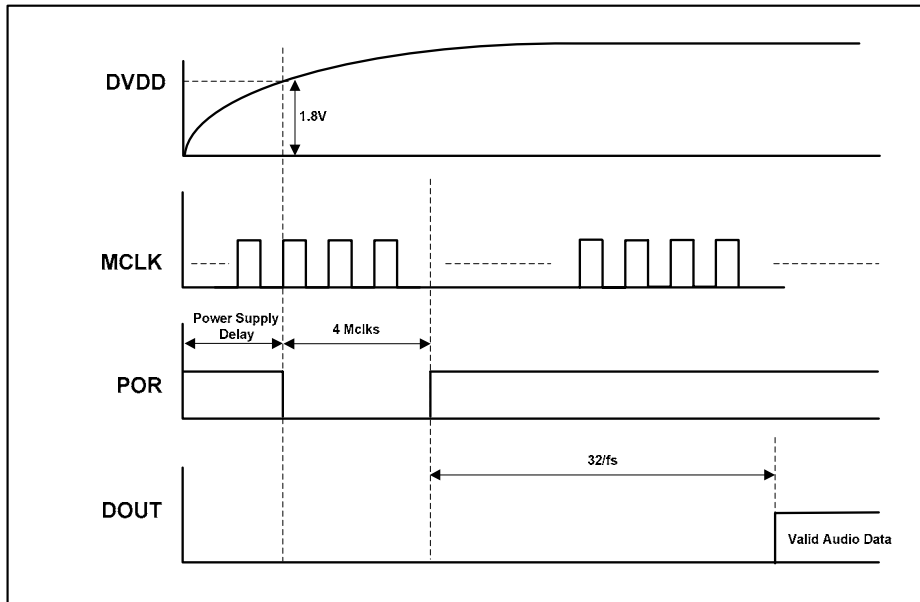

Figure 7 POR Timing

## DIGITAL FILTER CHARACTERISTICS

The WM8785 digital filter characteristics scale with sample rate.

PARAMETER	TEST CONDITIONS	MIN	TYP	MAX	UNIT
<b>ADC Sample Rate (Single Rate – 48KHz typically)</b>					
Passband	+/- 0.005dB	0		0.454fs	
	-6dB		0.5fs		
Passband Ripple				+/- 0.005	dB
Stopband		0.546fs			
Stopband Attenuation	f > 0.546fs	-85			dB
Group Delay			32/fs		s
<b>ADC Sample Rate (Dual Rate - 96kHz typically)</b>					
Passband	+/- 0.005dB	0		0.454fs	
	-6dB		0.5fs		
Passband Ripple				+/- 0.005	dB
Stopband		0.546fs			
Stopband Attenuation	f > 0.546fs	-85			dB
Group Delay			32/fs		s
<b>ADC Sample Rate (Quad Rate - 192kHz typically)</b>					
Passband	+/- 0.005dB	0		0.25fs	
	-3dB		0.45fs		
	-6dB		0.5fs		
Passband Ripple				+/- 0.005	dB
Stopband		0.75fs			
Stopband Attenuation	f > 0.75fs	-85			dB
Group Delay			10/fs		s
High Pass Filter Corner Frequency	-3dB		3.7		Hz
	-0.5dB		10.4		
	-0.1dB		21.6		

Table 1 Digital Filter Characteristics

## TERMINOLOGY

1. Stop Band Attenuation (dB) - the degree to which the frequency spectrum is attenuated (outside audio band)
2. Pass-band Ripple – any variation of the frequency response in the pass-band region

## HIGH PASS FILTER TRANSFER CHARACTERISTIC

The high pass filter response is defined by the following polynomial:

$$H(z) = \frac{1 - z^{-1}}{1 - (1 - \alpha)z^{-1}}$$

where  $\alpha = 2^{-11}$  for single rate (48k) mode  
 $\alpha = 2^{-12}$  for dual rate (96k) mode  
 $\alpha = 2^{-13}$  for quad rate (192k) mode

### FILTER RESPONSES

#### SINGLE RATE 48k

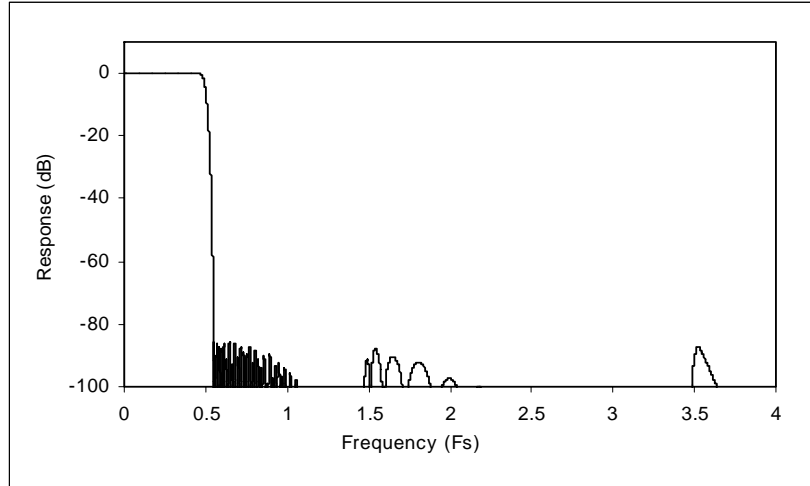

Figure 8 Single Rate 48k Filter Response

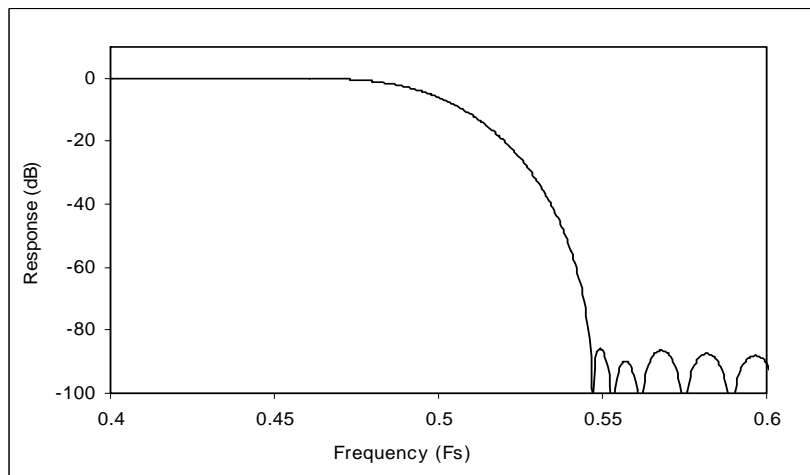

Figure 9 Single Rate 48k Filter Response

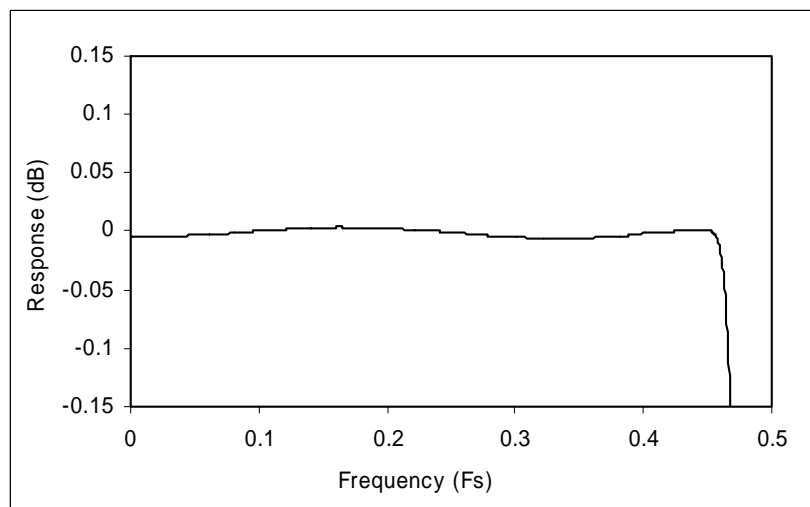

Figure 10 Single Rate 48k Filter Response

DUAL RATE 96k

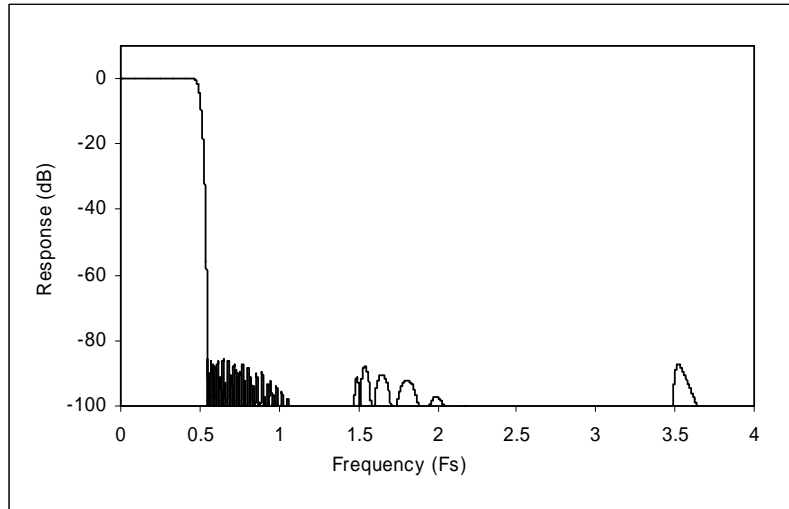

Figure 11 Dual Rate 96k Filter Response

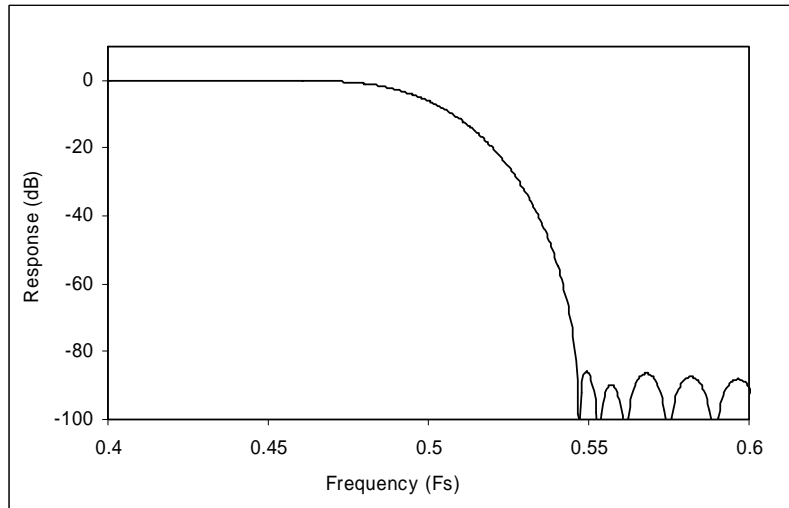

Figure 12 Dual Rate 96k Filter Response

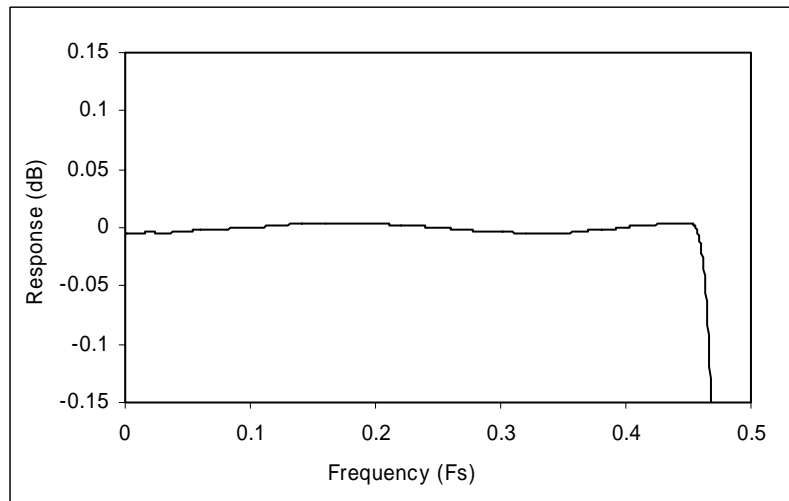

Figure 13 Dual Rate 96k Filter Response

QUAD RATE 192k

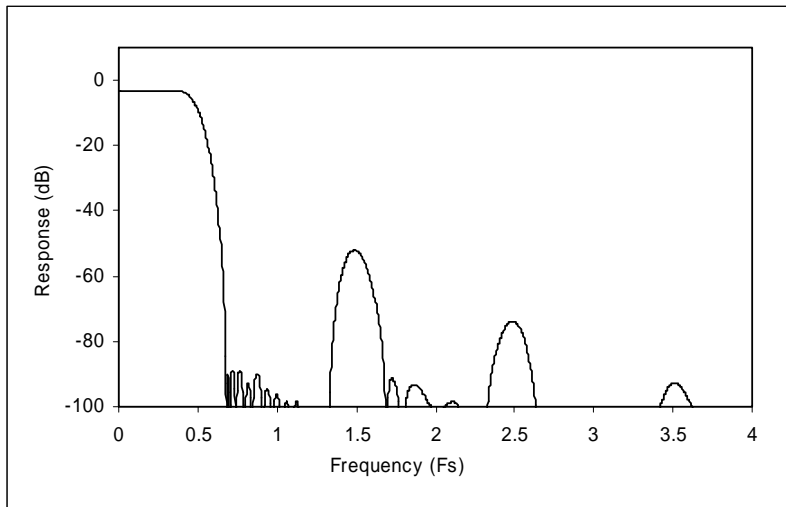

Figure 14 Quad Rate 192k Filter Response

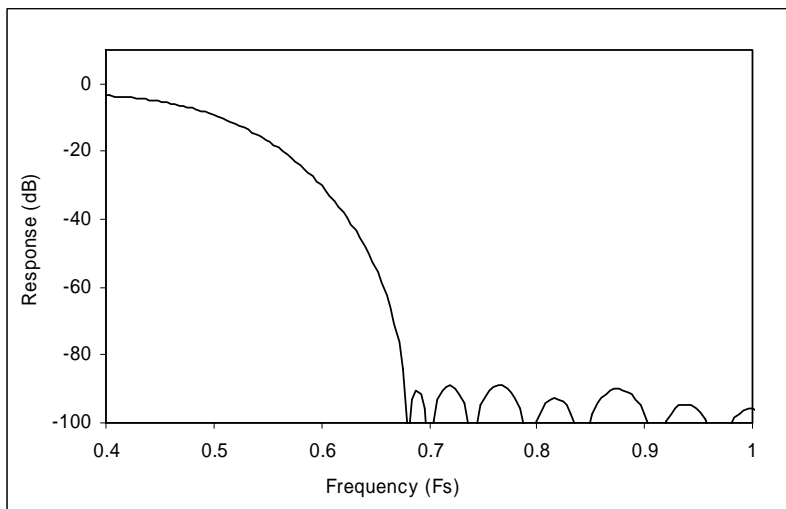

Figure 15 Quad Rate 192k Filter Response

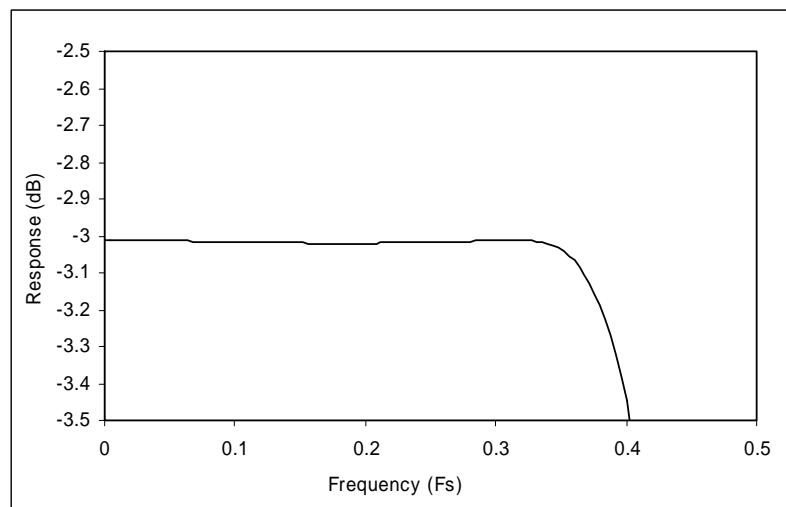

Figure 16 Quad Rate 192k Filter Response

HIGH PASS FILTER

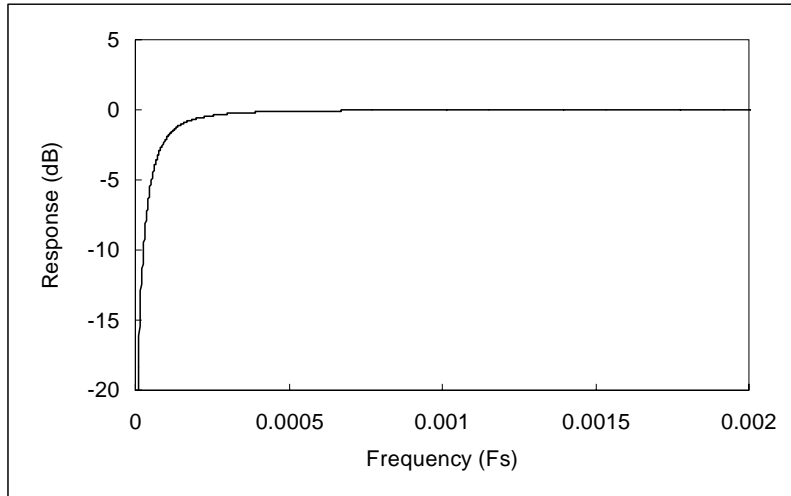

Figure 17 Single Rate 48k High Pass Filter Response

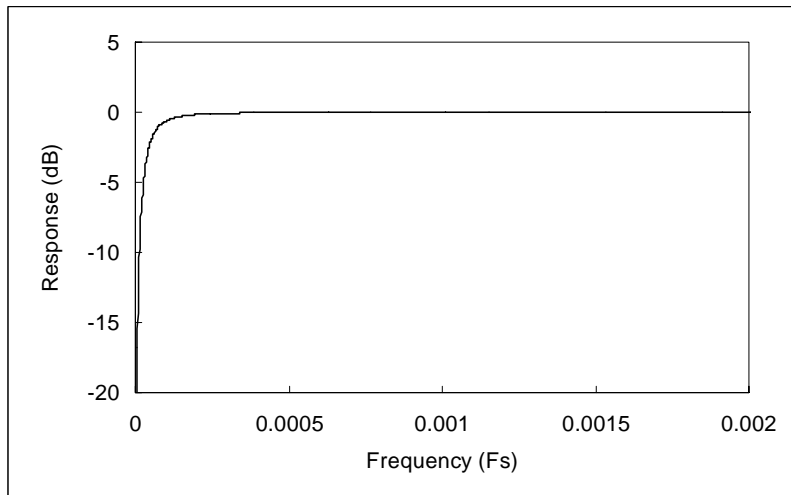

Figure 18 Dual Rate 96k High Pass Filter Response

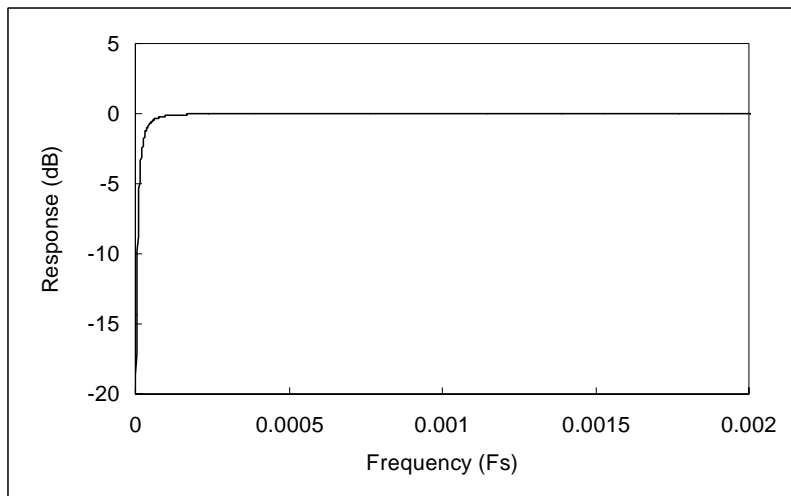

Figure 19 Quad Rate 192k High Pass Filter Response

## DEVICE DESCRIPTION

### INTRODUCTION

The WM8785 is a high performance stereo audio ADC designed for demanding recording applications such as DVD recorders, studio mixers, PVRs, and AV amplifiers. The WM8785 consists of stereo line level inputs, followed by a sigma-delta modulator and digital filtering.

The WM8785 uses a multi-bit high-order oversampling architecture delivering high SNR operating at oversampling ratios from 128fs to 32fs according to the sample rate. Sample rates from 8kHz to 192kHz are supported. The WM8785 supports master clock rates from 128fs to 768fs.

The digital filter is a high performance linear phase FIR filter. The digital filters are optimised for each sample rate. Also included is a selectable high pass filter to remove residual DC offsets from the input signal.

The output from the ADC is available on a configurable digital audio interface. It supports a number of audio data formats including I<sup>2</sup>S, Left justified and Right justified or DSP, and can operate in master or slave modes.

The WM8785 can be controlled through a 2 wire or 3 wire MPU control interface. It is fully compatible and an ideal partner for a range of industry standard microprocessors, controllers and DSPs. A TDM bus is supported for multiplexing data output.

The WM8785 can be powered down under software control to reduce system power consumption.

### DIGITAL AUDIO INTERFACE

The digital audio interface uses three pins:

- DOUT: ADC data output
- LRCLK: ADC data alignment clock
- BCLK: Bit clock, for synchronisation

The digital audio interface takes the data from the internal ADC digital filters and places it on DOUT and LRCLK. DOUT is the formatted digital audio data stream output from the ADC digital filters with left and right channels multiplexed together. LRCLK is an alignment clock that controls whether Left or Right channel data is present on the DOUT line. DOUT and LRCLK are synchronous with the BCLK signal with each data bit transition signified by a BCLK high to low transition. DOUT is always an output. BCLK and LRCLK maybe inputs or outputs depending whether the device is in Master or Slave mode, (see Master and Slave Mode Operation, below).

Four different audio data formats are supported:

- Left justified
- Right justified
- I<sup>2</sup>S
- DSP

They are described in Audio Data Formats, below. Refer to the Electrical Characteristic section for timing information.

### MASTER AND SLAVE MODE OPERATION

The WM8785 can be configured as either a master or slave mode device. As a master device the WM8785 generates BCLK and LRCLK and thus controls sequencing of the data transfer on DOUT. In slave mode, the WM8785 responds with data to clocks it receives over the digital audio interface. The mode can be selected by setting MCR=000 (see Table below). Master and slave modes are illustrated below.

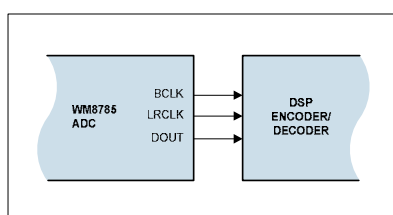

Figure 20a Master Mode

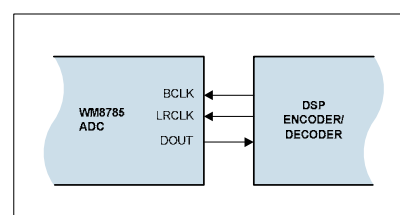
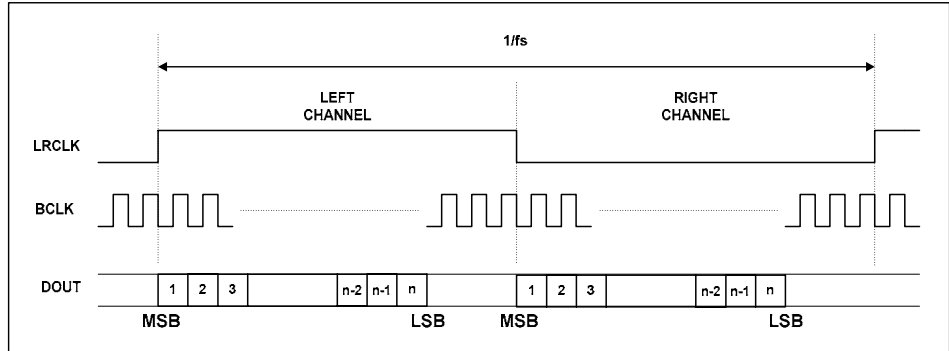

Figure 17b Slave Mode

**AUDIO DATA FORMATS**

In Left Justified mode, the MSB is available on the first rising edge of BCLK following an LRCLK transition. The other bits up to the LSB are then transmitted in order. Depending on word length, BCLK frequency and sample rate, there may be unused BCLK cycles before each LRCLK transition.



**Figure 21 Left Justified Audio Interface (assuming n-bit word length)**

In Right Justified mode, the LSB is available on the last rising edge of BCLK before an LRCLK transition. All other bits are transmitted before (MSB first). Depending on word length, BCLK frequency and sample rate, there may be unused BCLK cycles after each LRCLK transition.

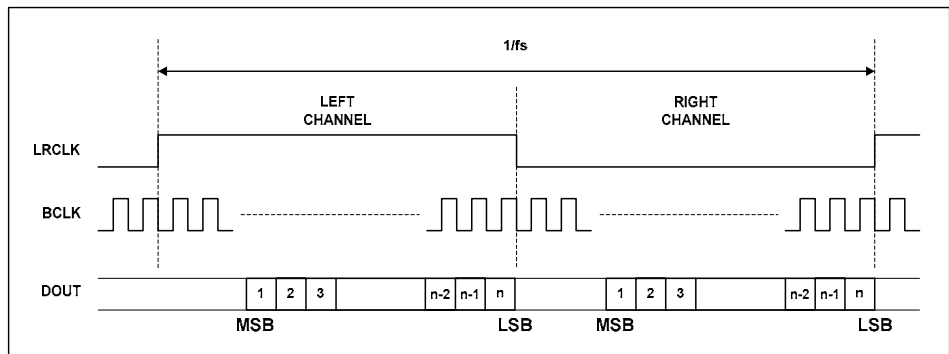

**Figure 22 Right Justified Audio Interface (assuming n-bit word length)**

In I<sup>2</sup>S mode, the MSB is available on the second rising edge of BCLK following an LRCLK transition. The other bits up to the LSB are then transmitted in order. Depending on word length, BCLK frequency and sample rate, there may be unused BCLK cycles between the LSB of one sample and the MSB of the next.

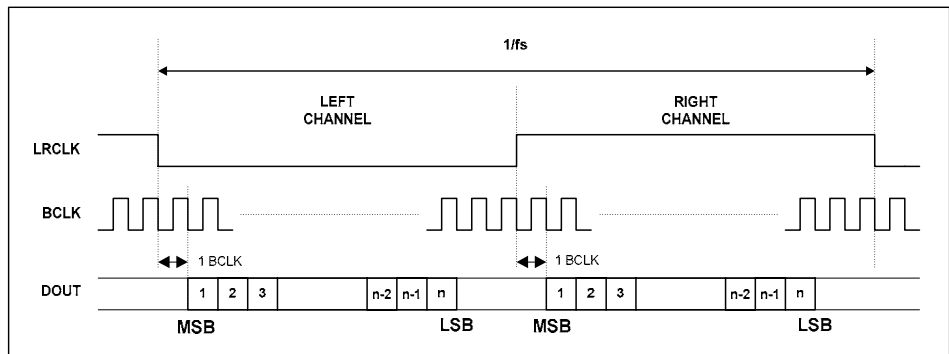

**Figure 23 I<sup>2</sup>S Justified Audio Interface (assuming n-bit word length)**

In DSP/PCM mode, the left channel MSB is available on either the 1<sup>st</sup> (mode B) or 2<sup>nd</sup> (mode A) rising edge of BCLK (selectable by LRP) following a rising edge of LRC. Right channel data immediately follows left channel data. Depending on word length, BCLK frequency and sample rate, there may be unused BCLK cycles between the LSB of the right channel data and the next sample.

In device master mode, the LRC output will resemble the frame pulse shown in Figure 24 and Figure 25. In device slave mode, Figure 26 and Figure 27, it is possible to use any length of frame pulse less than  $1/f_s$ , providing the falling edge of the frame pulse occurs greater than one BCLK period before the rising edge of the next frame pulse.

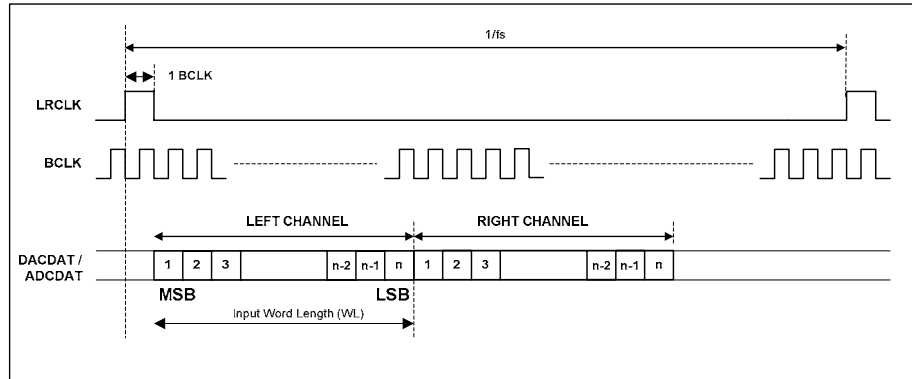

Figure 24 DSP/PCM Mode Audio Interface (mode A, LRP=0, Master)

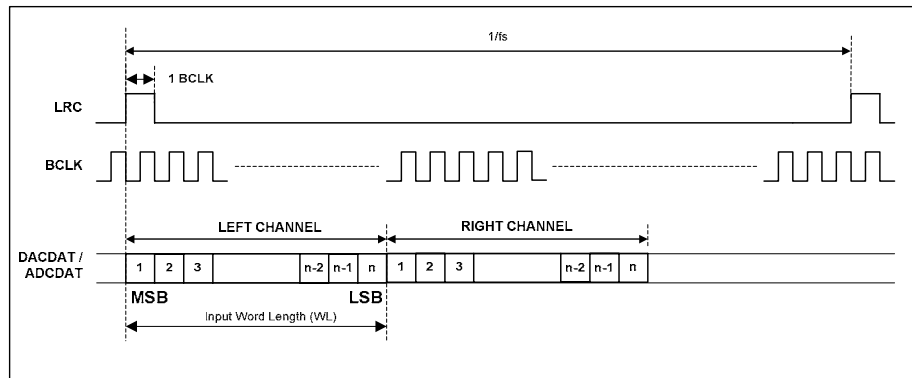

Figure 25 DSP/PCM Mode Audio Interface (mode B, LRP=1, Master)

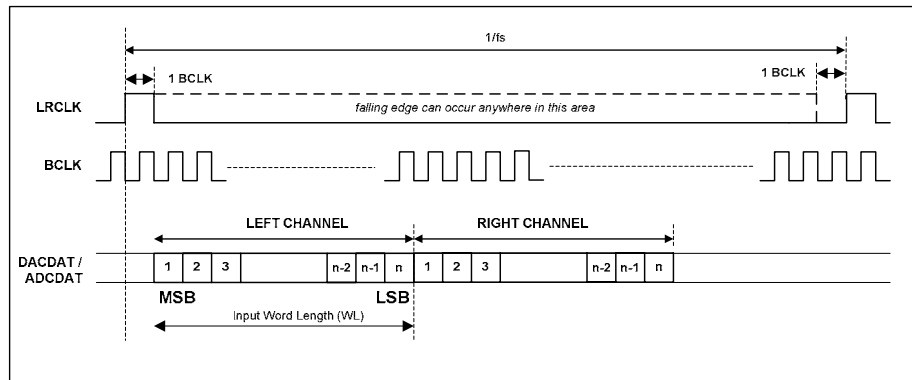

Figure 26 DSP/PCM Mode Audio Interface (mode A, LRP=0, Slave)

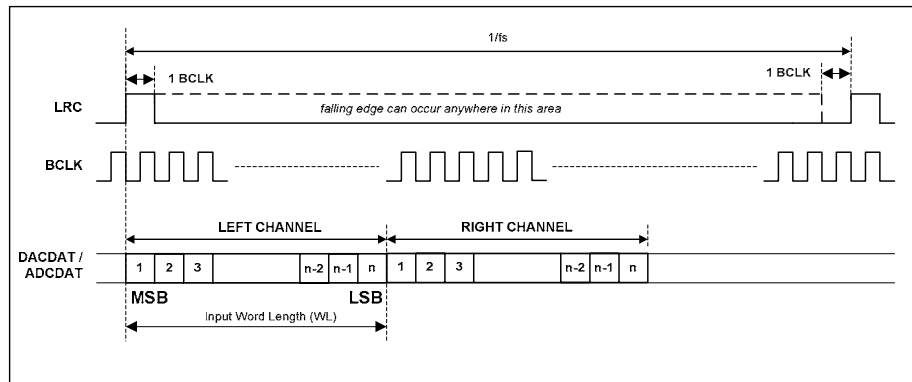

Figure 27 DSP/PCM Mode Audio Interface (mode B, LRP=1, Slave)

**AUDIO INTERFACE CONTROL**

The register bits controlling the audio interface are summarised below. Note that dynamically changing the software format may cause erroneous operation of the interfaces and is therefore not recommended.

All ADC data is 2's complement. The length of the digital audio data is programmable at 16/20/24 or 32 bits, as shown below. The ADC digital filters process data using 24 bits. If the WM8785 is programmed to output 16 or 20 bit data then it strips the LSBs from the 24 bit data. If the device is programmed to output 32 bits then it packs the LSBs with zeros.

In master mode LRCLK and BCLK are generated on chip. In slave mode they are received from an external source.

REGISTER ADDRESS	BIT	LABEL	DEFAULT	DESCRIPTION
R0 (00h) Sample Rate and Digital Audio Interface Format	6:5	FORMAT	10	Audio Data Format Select 11: DSP Format 10: I <sup>2</sup> S Format 01: Left justified 00: Right justified
R1 (01h) Digital Audio Interface Format and TDM	1:0	WL	10	Audio Data Word Length 11: 32 bits (see Note) 10: 24 bits 01: 20 bits 00: 16 bits
	2	LRP	0	right, left and I <sup>2</sup> S modes – LRCLK polarity 1 = invert LRCLK polarity 0 = normal LRCLK polarity  DSP Mode – A/B select 1 = MSB is available on 1st BCLK rising edge after LRC rising edge (mode B) 0 = MSB is available on 2nd BCLK rising edge after LRC rising edge (mode A)
	3	BCLKINV	0	BCLK invert bit (for master and slave modes) 0 = BCLK not inverted 1 = BCLK inverted
	4	LRSWAP	0	Left/Right channel swap 1 = swap left and right DAC data in audio interface 0 = output left and right data as normal

Table 2 Audio Data Format Control

**Note:** Right Justified mode does not support 32-bit data. If WL=11 in Right justified mode, the actual word length is 24 bits.

## DIGITAL HIGH PASS

The high pass filter can be enabled using the HPFL and HPFR bits (see digital filter characteristics)

REGISTER ADDRESS	BIT	LABEL	DEFAULT	DESCRIPTION
R2(02h) HPfilter , Output disable, Power down, Mono mode	0	HPFR	1	Digital High Pass Filter, Right Channel 0 = HPF Off 1 = HPF On
	1	HPFL	1	Digital High Pass Filter, Left Channel 0 = HPF Off 1 = HPF On

Table 3 Oversampling Ratio Selection

The high pass filter should only be disabled for procedures such as DC offset calibration. It should be noted that the output range of the ADC with a DC level applied and HPF disabled is as follows:

Maximum code: 7FDFB0

Minimum code: 802033

### DATA OUT PIN DISABLE

To prevent any communication problems on the Audio Interface, the interface can be disabled (DOUT tristated and floating) using the SDODIS bit.

REGISTER ADDRESS	BIT	LABEL	DEFAULT	DESCRIPTION
R2(02h) HP Filter , Output disable, Power down, Mono mode	2	SDODIS	0	DOUT serial data pin disable 0 = DOUT pin enabled 1 = DOUT pin off (high impedance)

Table 4 Oversampling Ratio Selection

### CONTROL INTERFACE

#### SELECTION OF CONTROL MODE

The WM8785 is controlled by writing to registers through a serial control interface. A control word consists of 16 bits. The first 7 bits (B15 to B9) are address bits that select which control register is accessed. The remaining 9 bits (B8 to B0) are register bits, corresponding to the 9 bits in each control register. The control interface can operate as either a 3-wire or 2-wire MPU interface. The CSB pin is sampled at power-up and selects the interface format. After power-up the pin is available to latch in control data in 3-wire interface mode.

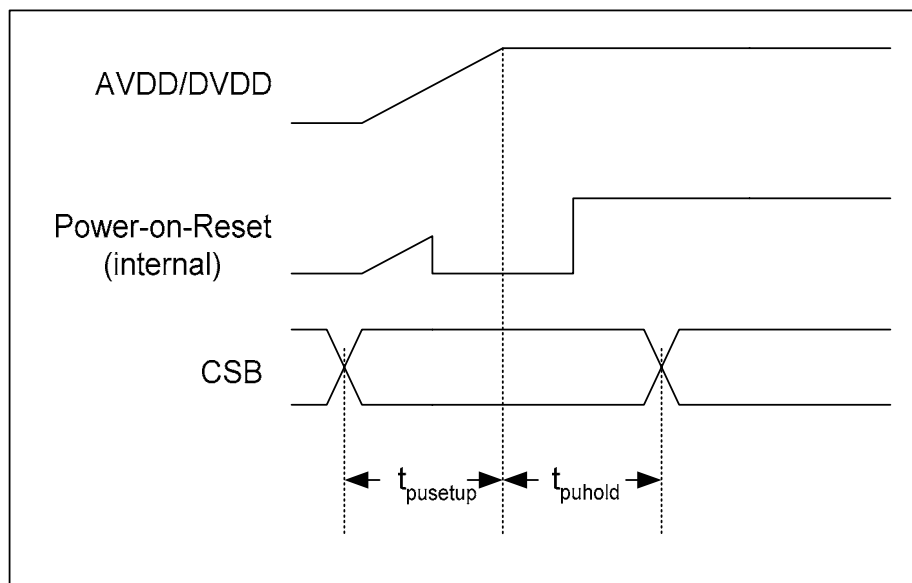

Figure 28 Control Interface Mode Selection

CSB PIN STATUS	INTERFACE FORMAT
Low	2 wire
High	3 wire

Table 5 Control Interface Mode Selection

SETUP/HOLD	TIME
t <sub>pusetup</sub>	250us
t <sub>puhold</sub>	250us

Table 6 Control Interface Mode Selection

### 3-WIRE SERIAL CONTROL MODE

In 3-wire mode, every rising edge of SCLK clocks in one data bit from the SDIN pin. A rising edge on CSB latches in a complete control word consisting of the last 16 bits.

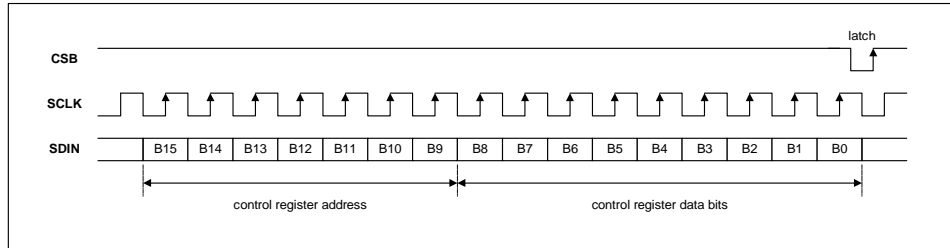

Figure 29 3-Wire Serial Control Interface

### 2-WIRE SERIAL CONTROL MODE

The WM8785 supports software control via a 2-wire serial bus. Many devices can be controlled by the same bus, and each device has a unique 7-bit address (this is not the same as the 7-bit address of each register in the WM8785).

The WM8785 operates as a slave device only. The controller indicates the start of data transfer with a high to low transition on SDIN while SCLK remains high. This indicates that a device address and data will follow. All devices on the 2-wire bus respond to the start condition and shift in the next eight bits on SDIN (7-bit address + Read/Write bit, MSB first). If the device address received matches the address of the WM8785 and the R/W bit is '0', indicating a write, then the WM8785 responds by pulling SDIN low on the next clock pulse (ACK). If the address is not recognised or the R/W bit is '1', the WM8785 returns to the idle condition and wait for a new start condition and valid address.

Once the WM8785 has acknowledged a correct address, the controller sends the first byte of control data (B15 to B8, i.e. the WM8785 register address plus the first bit of register data). The WM8785 then acknowledges the first data byte by pulling SDIN low for one clock pulse. The controller then sends the second byte of control data (B7 to B0, i.e. the remaining 8 bits of register data), and the WM8785 acknowledges again by pulling SDIN low.

The transfer of data is complete when there is a low to high transition on SDIN while SCLK is high. After receiving a complete address and data sequence the WM8785 returns to the idle state and waits for another start condition. If a start or stop condition is detected out of sequence at any point during data transfer (i.e. SDIN changes while SCLK is high), the device jumps to the idle condition.

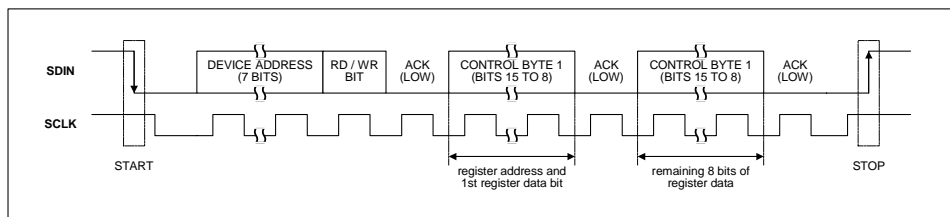

Figure 30 2-Wire Serial Control Interface

The WM8785 device address is 0011010.

### TIME DIVISION MULTIPLEXED DATA OUT

The WM8785 can be used to time division multiplex several data channels at once. For example, the diagram below illustrates 4 devices connected to the same TDM bus. While one DOUT pin is driving data, the others will be tri-stated.

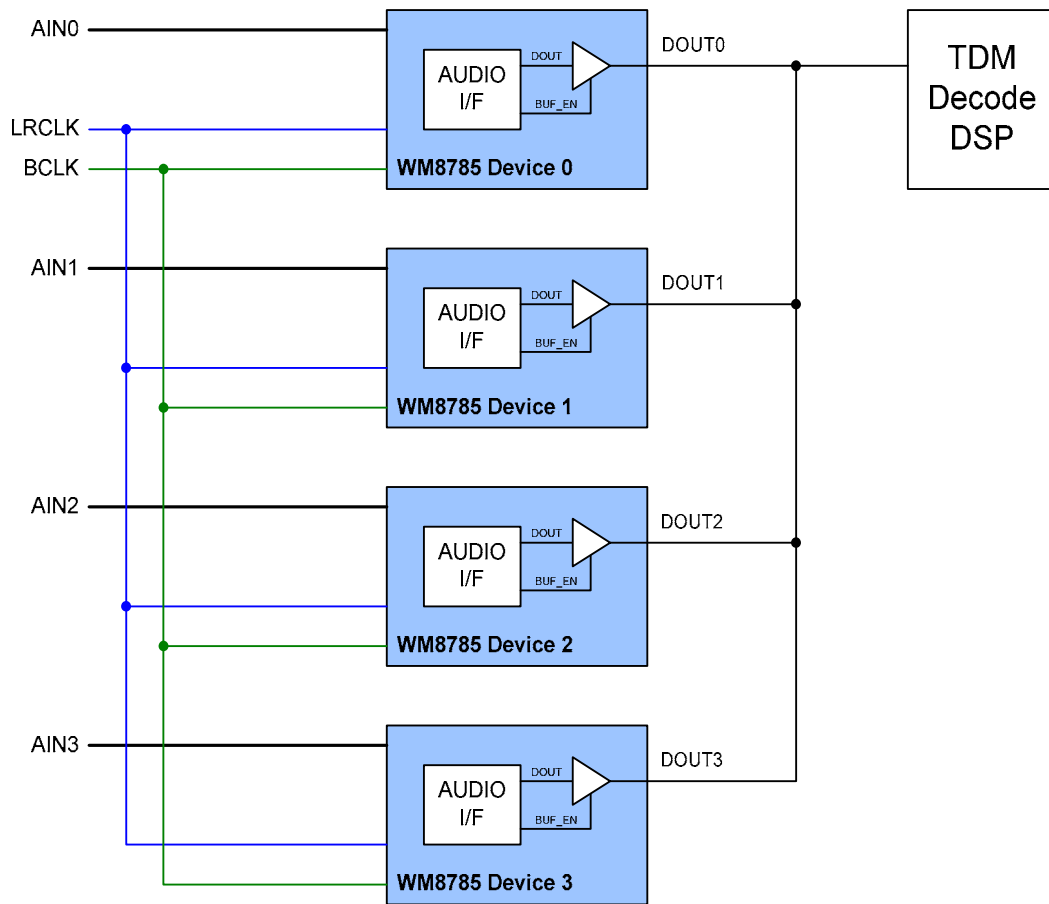

Figure 31 WM8785 in Time Division Multiplexing Setup

**Note:**

1. TDM is only available in slave mode.
2. Right justified mode is not supported

**TDM SELECTION**

The figure below indicates how data is multiplexed onto the TDM bus, in left justified mode. This assumes we have 4 devices, and each device has 2 data channels:

- LCHAN = left channel
- RCHAN = right channel

Each channel is allocated 32 BCLKs

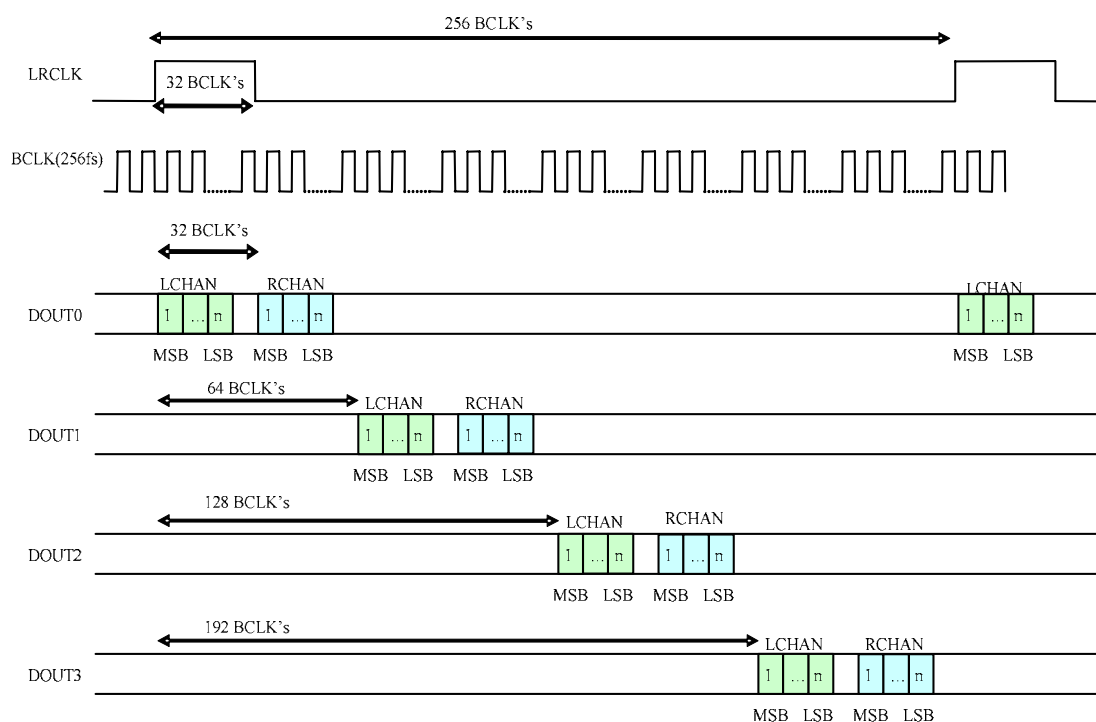

Figure 32 WM8785 in Time Division Multiplexing Left Justified Mode

Up to 4 devices (8 channels) can be supported, which would require 256 BCLKs per sample. (whereas 128 BCLKs will allow only 2 devices, or 4 channels). The table below shows the range of BCLK frequencies required.

BCLK RATE	DEVICES THAT CAN BE SUPPORTED	OVER-SAMPLE RATIOS SUPPORTED (SET BY OSR)
64 fs 128 fs 192 fs	1 1, 2 1, 2	Single/dual/quad rates all supported
256 fs	1, 2, 3, 4	

Table 7 Range of BCLK Frequencies Required

**Note:** MCLK frequency must always be greater or equal to BCLK frequency

To avoid bus contention all chips on the TDM should be programmed before DOUT is released after power up (DOUT is held at vss for 32 samples after power-up). Alternatively SDODIS should be set while devices are programmed (to tri-state DOUT).

Two registers must be set to enter TDM mode:

- DEVNO[2:0] sets the number of devices which are on the bus
- TDM[2:0] allocates a TDM slot to the device

REGISTER ADDRESS	BIT	LABEL	DEFAULT	DESCRIPTION
R1(h01) Clocking, Sample Rates, Oversampling and Signal Control	7:5	DEVNO[2:0]	000	Number of TDM Devices 000 = 1 Device 001 = 2 Devices 010 = 3 Devices 011 = 4 Devices

Table 8 DEVNO

REGISTER ADDRESS	BIT	LABEL	DEFAULT	DESCRIPTION
R2(h02) Clocking, Sample Rates, Oversampling and Signal Control	8:6	TDM[2:0]	000	Time Division Multiplexing Device Select 000 = Device 0 (no delay) 001 = Device 1 (64 BCLK delay) 010 = Device 2 (128 BCLK delay) 011 = Device 3 (192 BCLK delay)

Table 9 TDM

**Note:** When TDM is not required, the register will default to 000 (normal operation)

The figures below indicate TDM mode for I2S and DSP mode A.

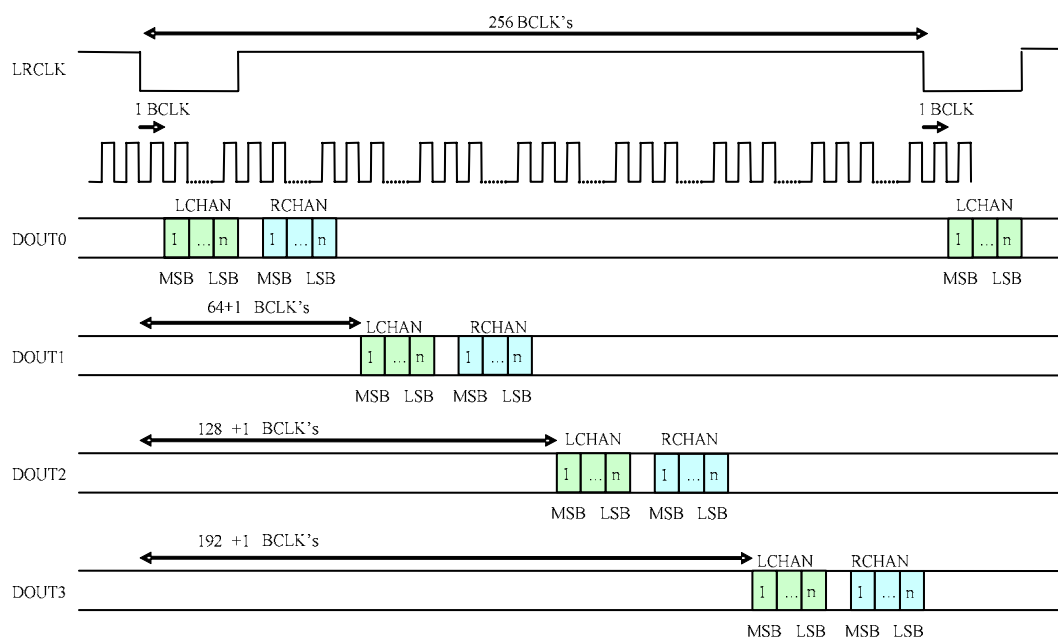

Figure 33 TDM Bus I2S Mode

## OVERSAMPLING RATIOS AND SIGMA-DELTA MODULATOR FREQUENCY

For correct operation of the device and optimal performance, the user must select the appropriate ADC modulator oversampling ratio. The oversampling ratio is selected using the OSR[1:0] bits.

REGISTER ADDRESS	BIT	LABEL	DEFAULT	DESCRIPTION
R0(h00) Signal Control	4:3	OSR[1:0]	00	Oversampling Ratio Control 00: Single Rate (128fs) 01: Dual Rate (64fs) 10: Quad Rate (32fs) 11: Not Valid

**Table 10 Oversampling Ratio Selection**

The WM8785 can operate at sample rates from 8kHz to 192kHz. The WM8785 uses a sigma-delta modulator that operates at frequencies between 1.024MHz and 6.144MHz

SAMPLING RATE (LRCLK)	OVERSAMPLING RATIO	SIGMA-DELTA MODULATOR FREQUENCY (MHZ)
8kHz	Single Rate (128fs)	1.024
32kHz	Single Rate (128fs)	4.096
44.1kHz	Single Rate (128fs)	5.6448
48kHz	Single Rate (128fs)	6.144
96kHz	Dual Rate (64fs)	6.144
192kHz	Quad Rate (32fs)	6.144

**Table 11 Sigma-delta Modulator Frequency**

## MASTER CLOCK AND AUDIO SAMPLE RATES

Master clock frequencies of 128f<sub>s</sub>, 192f<sub>s</sub>, 256f<sub>s</sub>, 384f<sub>s</sub>, 512f<sub>s</sub> and 768f<sub>s</sub> are supported. In slave mode the WM8785 automatically detects the audio sample rate. In Master mode the master clock frequency is selected using MCR[2:0] bits. This is described in table below.

REGISTER ADDRESS	BIT	LABEL	DEFAULT	DESCRIPTION
R0(h00) Clocking, Sample Rates,	2:0	MCR[2:0]	000	Master/Slave Selection 000: Slave Mode 001: Master Mode, 128fs 010: Master Mode, 192fs 011: Master Mode, 256fs 100: Master Mode, 384fs 101: Master Mode, 512fs 110: Master Mode, 768fs

**Table 12 Master Clock Frequency**

The master clock (MCLK) is used to operate the digital filters and the noise shaping circuits. The WM8785 supports a wide range of master clock frequencies, and can generate many commonly used audio sample rates directly from the master clock. Table 1 shows the recommended master clock frequencies for different sample rates

SAMPLING RATE (LRCLK)	OVERSAMPLING RATIO	MASTER CLOCK FREQUENCY (MHZ)					
		128fs	192fs	256fs	384fs	512fs	768fs
32kHz	Single Rate	-	-	8.192	12.288	16.384	24.576
44.1kHz	Single Rate	-	-	11.2896	16.9344	22.5792	33.8688
48kHz	Single Rate	-	-	12.288	18.432	24.576	36.864
96kHz	Dual Rate	-	-	24.576	36.864	-	-
192kHz	Quad Rate	24.576	36.864	-	-	-	-

Table 13 Slave Mode: Recommended Master Clock Frequency Selection

## MLCK AND LRCLK PHASE RELATIONSHIP

The WM8785 does not require a specific phase relationship between MLCK and LRCLK. If the relationship between MCLK and LRCLK changes by more than +/-8 BCLKs in a 64 BCLK frame, the WM8785 will attempt to re-synchronise. During re-synchronisation, data samples may be dropped or duplicated.

## POWER DOWN CONTROL

The WM8785 can be powered down by setting the PWRDNL and PWRDNR bits. This is described in the table below.

REGISTER ADDRESS	BIT	LABEL	DEFAULT	DESCRIPTION
R2(02h) Signal control	3	PWRDNR	0	Power Down Right Channel 0 = Power On 1 = Power Off
	4	PWRDNL	0	Power Down Left Channel 0 = Power On 1 = Power Off

Table 14 Power Down Control

**REGISTER MAP**

REGISTER	ADDRESS	REMARK	BIT8	BIT7	BIT6	BIT5	BIT4	BIT3	BIT2	BIT1	BIT0	DEFAULT
R0(00h)	00_0000	Sample Rate And Audio IF Format	0	0	FORMAT		OSR		MCR			0_0000_0011
R1(01h)	00_0001	Audio IF Format And TDM	0	DEVNO			LRSWP	BCLKINV	LRP	WL		0_0000_1010
R2(02h)	00_0010	Signal Control	TDM		0		PWRDNL	PWRDNR	SODDIS	HPFL	HPFR	0_0000_0011
R7(07h)	00_0111	Reset	Writing to reg 7 will cause software reset									0_0000_0000

**Table 15 Register Map for Control Interface****Notes:**

1. All unused register bits should be set to zero
2. The interface will initiate SWRB whenever R7 is addressed, regardless of the data input.
3. SWRB is released on the next register write or after 4 MCLK cycles (which ever occurs first).
4. Until the SWRB is released, DOUT is forced to zero.
5. DOUT remains zero for a count of 32 sample clocks SWRB is released, this count is driven by MCLK and is independent of any external LRCLK.

APPLICATIONS INFORMATION

RECOMMENDED EXTERNAL COMPONENTS

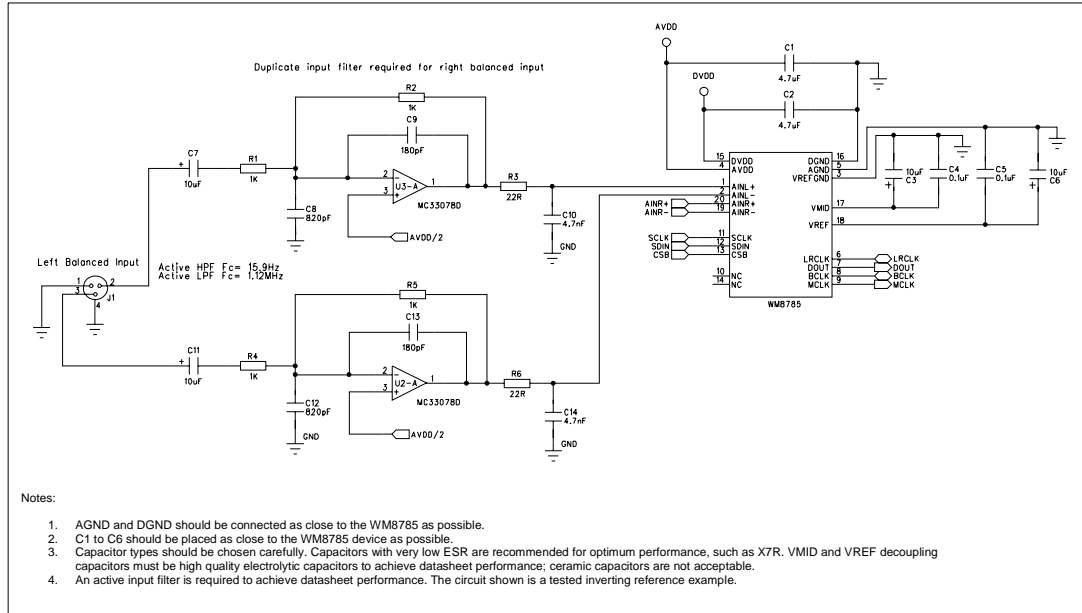
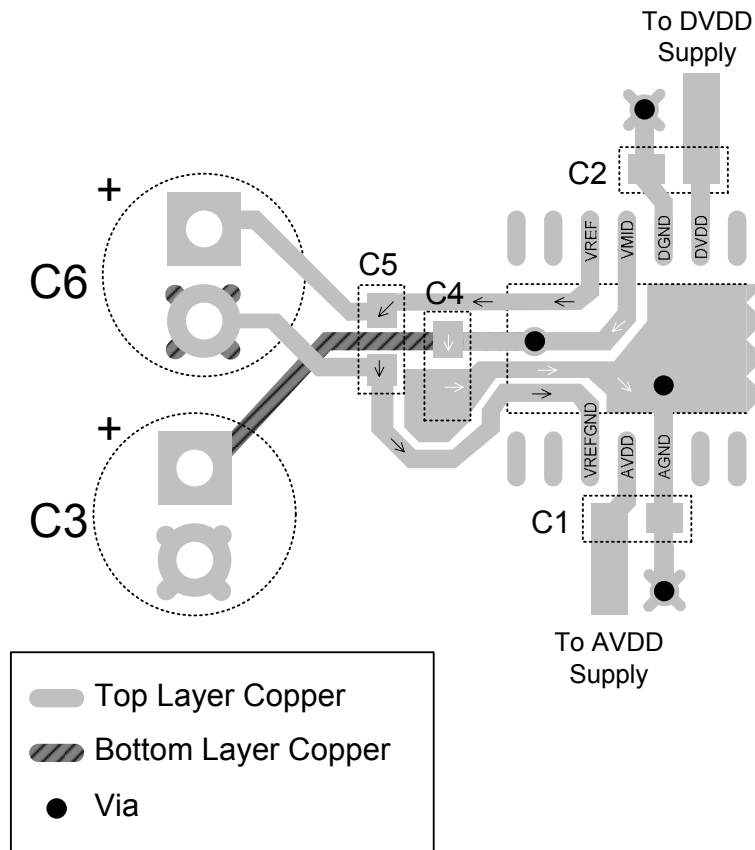

Figure 34 External Component Diagram

## RECOMMENDED PCB LAYOUT

The WM8785 is sensitive to the routing of the ground return currents for VREF, VMID and AVDD and care should be taken to ensure that these currents do not interfere. Figure 35 below shows a recommended PCB layout (with high frequency current paths) for the WM8785 that will demonstrate datasheet performance:

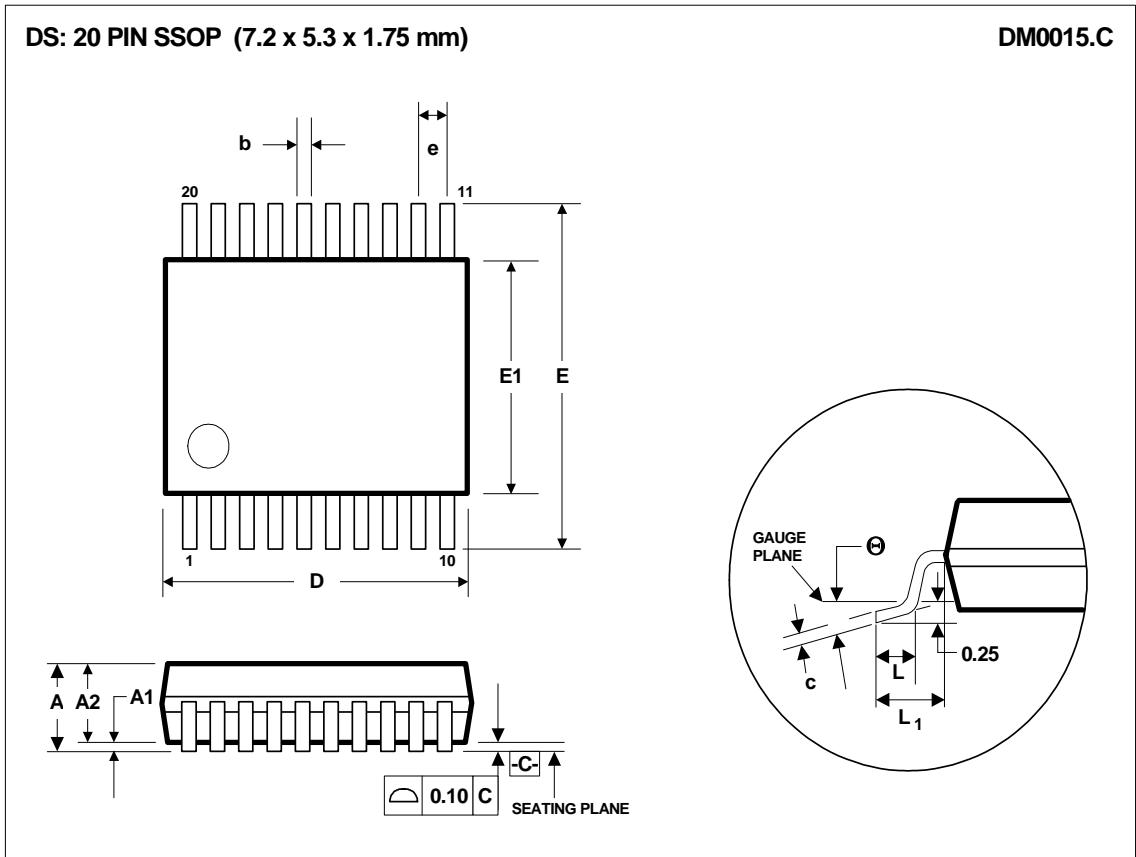

**Figure 35 Recommended PCB Layout for VREF, VMID, AVDD and DVDD Decoupling**

### Notes:

1. High frequency noise on VREF is decoupled through C5, and the return path should be directly to VREFGND.
2. The route from the negative terminal of C6 to C5 and then to VREFGND should be made on the top layer only and should not connect to the ground flood on the top layer. This ensures that the VREF return current is returned directly to VREFGND as shown by the black arrows.
3. The negative terminal of C6 should be connected to the ground plane on the underside of the board only.
4. High frequency noise on VMID is decoupled through C4, and the return path should be directly to AGND.
5. Via to bottom layer on VMID used to connect to bottom layer route to positive terminal of C3.
6. The route from C4 to AGND should be made on the top layer only. This ensures that the VMID return current is returned to AGND as shown by the white arrows.
7. AVDD is decoupled to AGND through C1. The ground return currents are not shown in this diagram.
8. DVDD is decoupled to DGND through C2. The ground return currents are not shown in this diagram.
9. DGND should not be connected directly to the ground flood on the top layer under the WM8785. This will ensure that noise in the digital ground does not interfere with the critical routing of VREF and VMID.
10. Bottom layer ground flood not shown for clarity.
11. See the WM8785 Evaluation Board for an example of this layout in use.

PACKAGE DIMENSIONS



Symbols	Dimensions (mm)		
	MIN	NOM	MAX
A	-----	-----	2.0
A <sub>1</sub>	0.05	-----	-----
A <sub>2</sub>	1.65	1.75	1.85
b	0.22	0.30	0.38
c	0.09	-----	0.25
D	6.90	7.20	7.50
e	0.65 BSC		
E	7.40	7.80	8.20
E <sub>1</sub>	5.00	5.30	5.60
L	0.55	0.75	0.95
L <sub>1</sub>	1.25 REF		
θ	0°	4°	8°
REF:	JEDEC.95, MO-150		

- NOTES:  
 A. ALL LINEAR DIMENSIONS ARE IN MILLIMETERS.  
 B. THIS DRAWING IS SUBJECT TO CHANGE WITHOUT NOTICE.  
 C. BODY DIMENSIONS DO NOT INCLUDE MOLD FLASH OR PROTRUSION, NOT TO EXCEED 0.20MM.  
 D. MEETS JEDEC.95 MO-150, VARIATION = AE. REFER TO THIS SPECIFICATION FOR FURTHER DETAILS.

## IMPORTANT NOTICE

Wolfson Microelectronics plc ("Wolfson") products and services are sold subject to Wolfson's terms and conditions of sale, delivery and payment supplied at the time of order acknowledgement.

Wolfson warrants performance of its products to the specifications in effect at the date of shipment. Wolfson reserves the right to make changes to its products and specifications or to discontinue any product or service without notice. Customers should therefore obtain the latest version of relevant information from Wolfson to verify that the information is current.

Testing and other quality control techniques are utilised to the extent Wolfson deems necessary to support its warranty. Specific testing of all parameters of each device is not necessarily performed unless required by law or regulation.

In order to minimise risks associated with customer applications, the customer must use adequate design and operating safeguards to minimise inherent or procedural hazards. Wolfson is not liable for applications assistance or customer product design. The customer is solely responsible for its selection and use of Wolfson products. Wolfson is not liable for such selection or use nor for use of any circuitry other than circuitry entirely embodied in a Wolfson product.

Wolfson's products are not intended for use in life support systems, appliances, nuclear systems or systems where malfunction can reasonably be expected to result in personal injury, death or severe property or environmental damage. Any use of products by the customer for such purposes is at the customer's own risk.

Wolfson does not grant any licence (express or implied) under any patent right, copyright, mask work right or other intellectual property right of Wolfson covering or relating to any combination, machine, or process in which its products or services might be or are used. Any provision or publication of any third party's products or services does not constitute Wolfson's approval, licence, warranty or endorsement thereof. Any third party trade marks contained in this document belong to the respective third party owner.

Reproduction of information from Wolfson datasheets is permissible only if reproduction is without alteration and is accompanied by all associated copyright, proprietary and other notices (including this notice) and conditions. Wolfson is not liable for any unauthorised alteration of such information or for any reliance placed thereon.

Any representations made, warranties given, and/or liabilities accepted by any person which differ from those contained in this datasheet or in Wolfson's standard terms and conditions of sale, delivery and payment are made, given and/or accepted at that person's own risk. Wolfson is not liable for any such representations, warranties or liabilities or for any reliance placed thereon by any person.

### ADDRESS:

Wolfson Microelectronics plc  
Westfield House  
26 Westfield Road  
Edinburgh  
EH11 2QB  
United Kingdom

Tel :: +44 (0)131 272 7000

Fax :: +44 (0)131 272 7001

Email :: sales@wolfsonmicro.com